

**HIGHLEAD**

**GC2268**

**CYLINDER-BED UNISON FEED SEWING MACHINE**

**Instruction Manual**  
**Parts Catalog**

**SHANGHAI BIAOZHUN HAILING SEWING MACHINERY CO., LTD.**

---

**----- CONTENTS -----**

<b>PRECAUTIONS BEFORE STARTING OPERATION .....</b>	<b>1</b>
1) <b>Safety precautions.....</b>	<b>1</b>
2) <b>Precaution before Starting Operation .....</b>	<b>1</b>
3) <b>Precaution for Operating Conditions .....</b>	<b>1</b>
<b>CAUTIONS ON USE .....</b>	<b>1</b>
<b>1. LUBRICATION.....</b>	<b>1</b>
<b>2. ATTACHING THE NEEDLE.....</b>	<b>2</b>
<b>3. ATTACHING/REMOVING THE BOBBIN CASE.....</b>	<b>2</b>
<b>4. WINDING A BOBBIN .....</b>	<b>2</b>
<b>5. PLACING A BOBBIN IN THE BOBIN CASE.....</b>	<b>3</b>
<b>6. HREADING THE MACHINE HEAD .....</b>	<b>3</b>
<b>7. ADJUSTING THE TITCH LENGTH.....</b>	<b>3</b>
<b>8. THREAD TENSION .....</b>	<b>4</b>
<b>9. THREAD TAKE-UP SPRING .....</b>	<b>4</b>
<b>10. ADJUSTING THE PRESSURE OF THE PRESSER FOOT .....</b>	<b>5</b>
<b>11. ADJUSTING THE PRESSER FOOT AND THE WALKING FOOT.....</b>	<b>5</b>
<b>12. HEIGHT OF THE FEED DOG .....</b>	<b>5</b>
<b>13. NEEDLE-TO-HOOK RELATIONSHIP .....</b>	<b>6</b>
<b>14. ADJUSTING THE NEEDLE GUARD OF THE HOOK .....</b>	<b>6</b>
<b>15. ADJUSTING THE BOBBIN CASE OPENNING LEVER .....</b>	<b>7</b>
<b>16. ADJUSTING THE LONGITUDINAL POSITION OF THE NEEDLE BAR FRAME.....</b>	<b>7</b>
<b>17. SAFETY MECHANISM .....</b>	<b>7</b>
<b>18. REPLACING THE TIMING BELT .....</b>	<b>8</b>
<b>19. INSTALLATION OF PRESSER FOOT LIFTER SETTING .....</b>	<b>8</b>

**----- PARTS LIST -----**

<b>A. ARM BED AND ITS ACCESSORIES .....</b>	<b>9</b>
<b>B. THREAD TENSION REGULATOR MECHANISM.....</b>	<b>11</b>
<b>C. C.TAKE-UP THREAD AND ARM SHAFT MECHANISM .....</b>	<b>13</b>
<b>D. D.NEEDLE BAR AND ROTATING HOOK SHAFT MECHANISM .....</b>	<b>16</b>
<b>E. E.PRESSER FOOT FEEDING MECHANISM .....</b>	<b>19</b>
<b>F. F.STITCH REGULATOR MECHANISM .....</b>	<b>22</b>
<b>G. G.ACCESSORIES .....</b>	<b>25</b>

---

---

## PRECAUTIONS BEFORE STARTING OPERATION

### 1. Safety precautions

- 1) When turning the power on, keep your hands and fingers away from the area around/under the needle and the area around the pulley.
- 2) Power must be turned off when the machine is not in use, or when the operator leaves the seat.
- 3) Power must be turned off when tilting the machine head, installing or removing the “V” belt, adjusting the machine, or when replacing.
- 4) Avoid placing fingers, hairs, bars etc., near the pulley, “V” belt, bobbin winder pulley, or motor when the machine is in operation.
- 5) Do not insert fingers into the thread take-up cover, under/around the needle, or pulley when the machine is in operation.

### 2. Precautions before starting operation

- 1) Do not operate the machine before lubricating it.
- 2) When a new sewing machine is first turned on, verify the rotational direction of the pulley with the power on (the pulley should rotate counterclockwise when viewed from pulley) .
- 3) Verify the voltage and (single or three) phase with those given on the machine nameplate.

### 3. Precautions for operating conditions

- 1) Avoid using the machine at abnormally high temperatures (35°C or higher) or low temperatures (5°C or lower) .
- 2) Avoid using the machine in dusty conditions.

## CAUTIONS ON USE:

### 1. LUBRICATION (Fig.1、 Fig.2、 Fig.3)

#### 1) Before Starting the Sewing Machine

Prior to operation, apply adequate amount of oil to the points marked with the arrows.

#### 2) Lubricating the hook and hook shaft saddle

Shift the slide plate, and apply two or three drops of oil every day to the hole shown with the arrow A. And fore of five drops of oil every day to the felt shown with the arrow B.

#### 3) Lubricating the feed bar

Prior to operation, apply two or three drops of oil to the holes shown with the arrows C, D and E without fail.

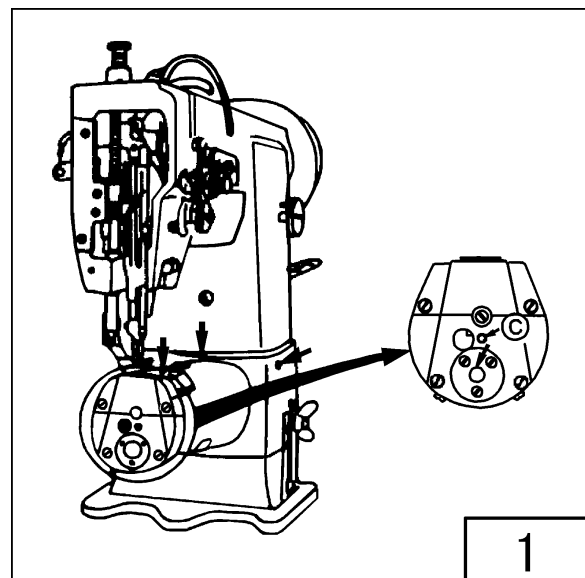

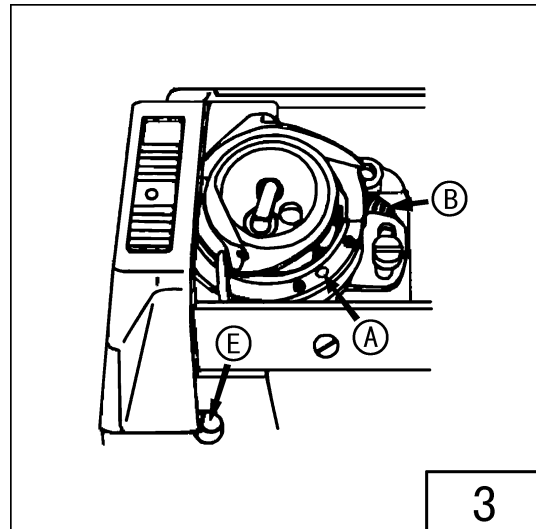
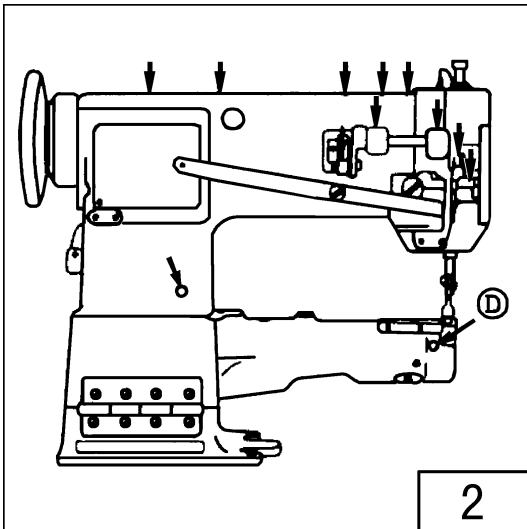

## 2. ATTACHING THE NEEDLE (Fig.3)

Turn OFF the power to the motor.

- 1) Turn the handwheel to move the needle bar up to its highest position.
- 2) Loosen needle clamp screw(2). Hold needle so that its indented part A faces exactly to the right.
- 3) Insert the needle into the needle bar until it will go no further.
- 4) Securely tighten the needle clamp screw (2).

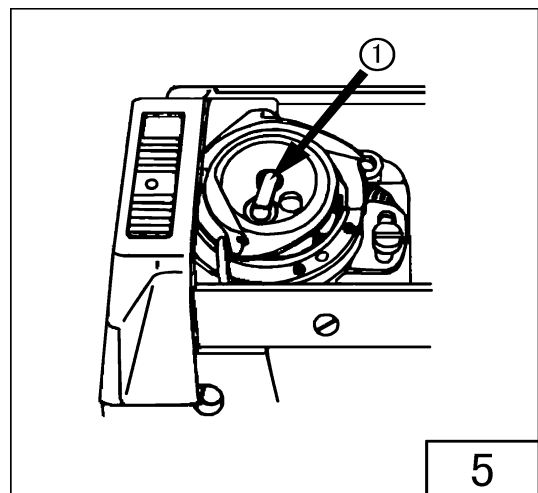
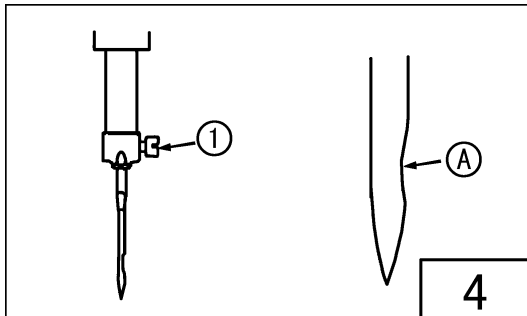

## 3. ATTACHING/REMOVING THE BOBBIN CASE (Fig.5)

- 1) Raise lever (1) of the hook, and remove the bobbin case together with the bobbin in it.
- 2) Fit the bobbin case into the hook driving shaft, and tilt the lever.

## 4. WINDING A BOBBIN (Fig.6)

- 1) Route the thread in the order of A, B and C before winding it round the bobbin several times.
- 2) Set bobbin presser (1) down to bring the winder in contact with the belt.
- 3) Adjust screw (2) to adjust the amount of thread to be

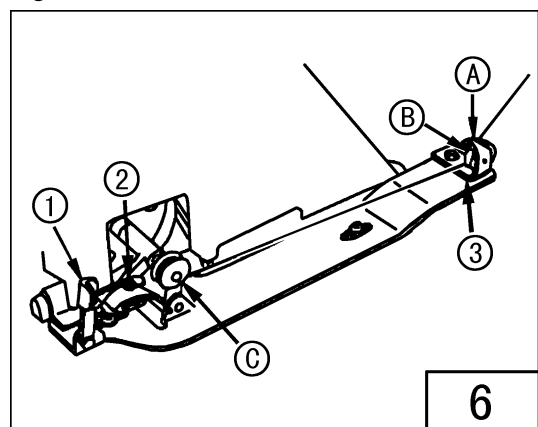

would round the bobbin so that the bobbin is wound with thread about 80% of its capacity. Turn the screw clockwise to increase the amount of thread is evenly wound round the bobbin.

- 4) If thread is wound unevenly wound the bobbin, right or left so that thread is evenly wound round the bobbin.
- 5) The moment the bobbin has been wound up, the bobbin presser is released, and the bobbin winder will stop automatically.

### 5. PLACING A BOBBIN IN THE BOBIN CASE (Fig.7)

- 1) Hold a bobbin so that the end of the thread wound round the bobbin is directed to the right and put it into the bobbin case.
- 2) Pass the thread in threading slit (1) in the bobbin case, route it under the tension spring and draw it out from notch.

**(Caution) As long as the bobbin is correctly the thread in direction A makes the bobbin rotate in direction B.**

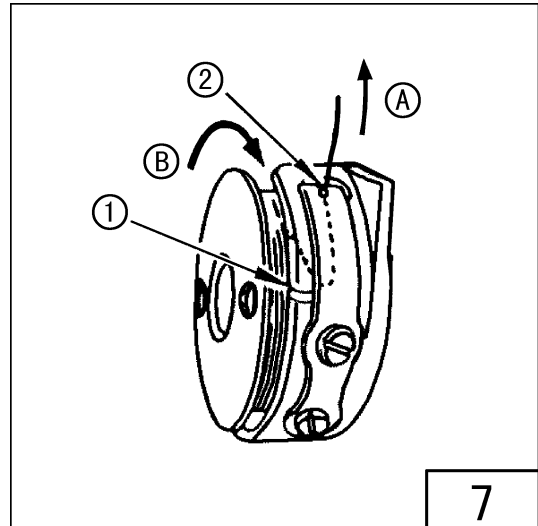

### 6. THREADING THE MACHINE HEAD (Fig.8)

Thread the machine as illustrated in the figure in the order of (1) through (13).

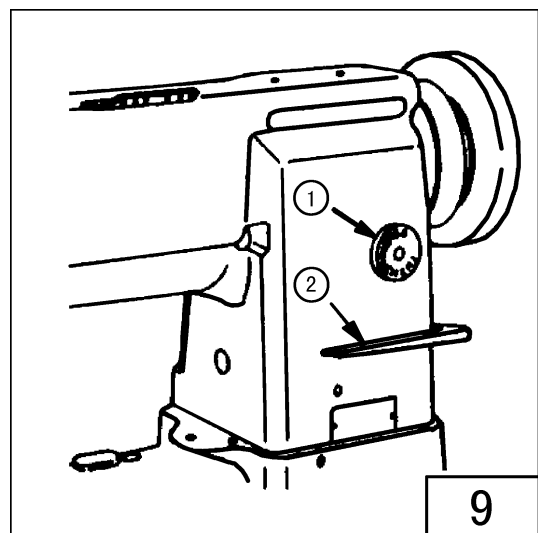
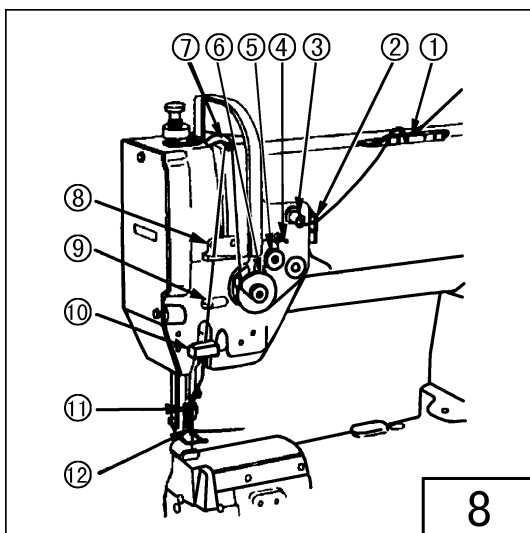

### 7. ADJUSTING THE TITCH LENGTH (Fig.9)

Turn stitch length dial (1) counter-clockwise to bring the desired value to the top of the dial so that the value is aligned with the pin.

#### Reverse feed stitching

- 1) Push down feed lever (2)

- 2) The machine performs reverse feed stitching as long as the lever is held depressed.
- 3) The moment you release the lever, the machine resumed the normal stitching mode.

## 8. THREAD TENSION

- 1) Adjusting the needle thread tension (Fig.10)

Turn tension nut (1) clockwise (toward A) to increase the needle thread tension, or counter clocking (toward B) to decrease it .

- 2) Adjusting the bobbin thread tension (Fig.11)

Turn tension screw (2) clockwise (toward C) to increase the bobbin thread tension, or counter clockwise (toward D) to decrease it.

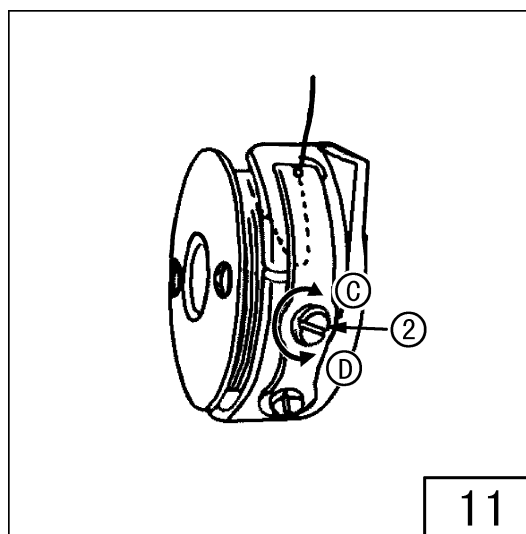
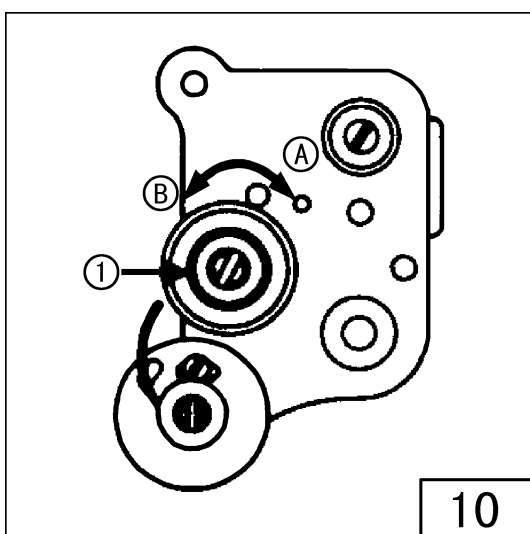

## 9. THREAD TAKE-UP SPRING (Fig.12)

- 1) **To change the stroke of thread take-up spring (1)**

(1) Loosen screw (2) in the stopper, and move stopper (3) to the right or left.

(2) Move the stopper to the right to increase the stroke of the thread take-up spring , or to the left to decrease it.

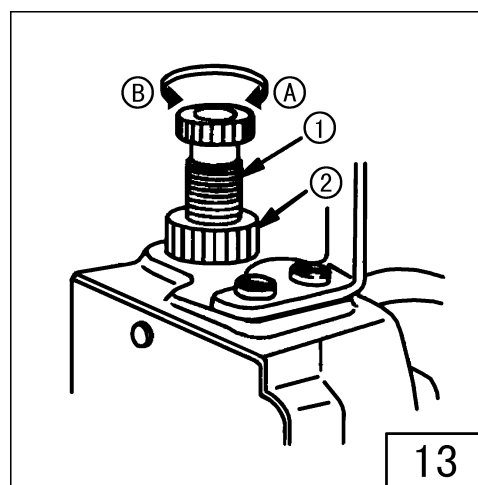
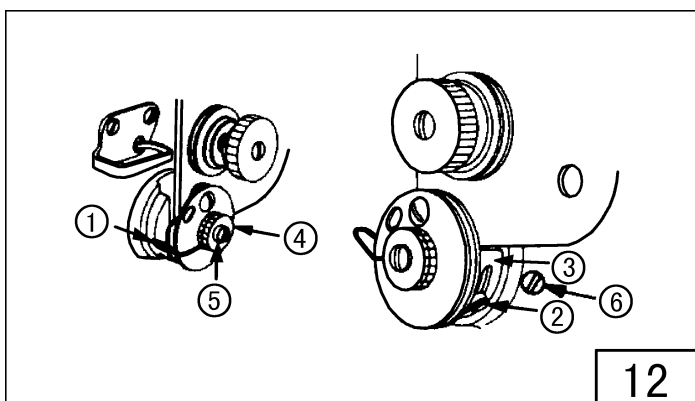

- 1) **To change the tension of the thread take-up spring**

Loosen nut (4) and screw (6). Turn spring shaft (5) counter clockwise to increase the tension of the

spring, or clockwise to decrease it . Fit a screwdriver in the spring shaft and turn it until the desired tension is provided.

### 10. ADJUSTING THE PRESSURE OF THE PRESSER FOOT (Fig.13)

- 1) Turn pressure spring regulator (1) clockwise (toward A) to increase the pressure of the presser foot, or counter clockwise (toward B) to decrease it.
- 2) After the adjustment, securely tighten nut (2) of the regulator

### 11. ADJUSTING THE PRESSER FOOT AND THE WALKING FOOT

- 1) Loosen not (1), and change the position of the cam rod boss accordingly. (Fig.14)

Highest position---The stroke is maximized. A

Lowest position--- The stroke is minimized. B。

- 2) Alternate vertical motions of the walking foot and presser foot (Fig.15)

The alternate vertical strokes of the walking foot and presser foot

(1) Loosen screw (2) of the top feed crank..

(2) Bring the thread take-up lever to its highest position, and lower the presser bar lifting lever. Move top feed crank (3) to left A to increase the stroke of the presser foot , or to the right B to increase it.

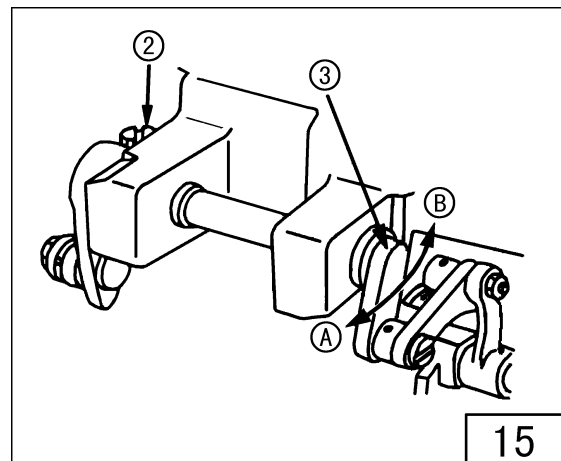
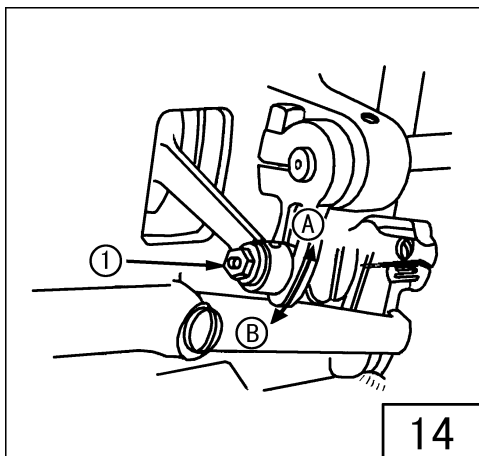

### 12. HEIGHT OF THE FEED DOG (Fig.16)

Feed dog(1) has been factory-adjusted to jut out 1 mm from the surface of throat plate (2). When the feed dog height needs to be adjusted according the sewing conditions or after the feed dog is replaced, follow the procedure described below.

- 1) Maximize the feed dog height.
- 2) Loosen screw (3) in the feed dog.
- 3) Adjust the feed dog height comparatively higher than the standard height , and temporarily fix it at that position.

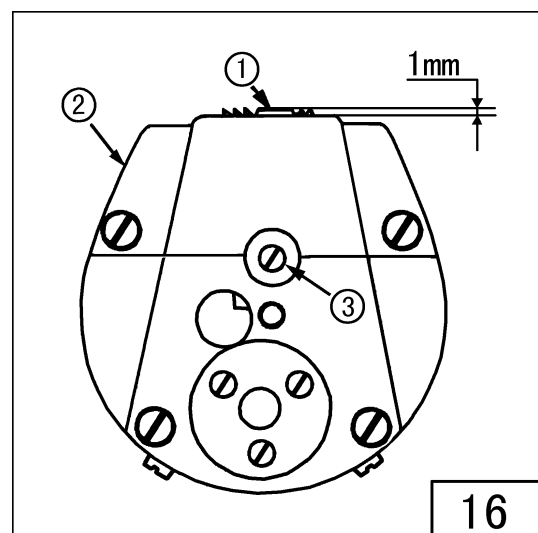

- Now, adjust the height of the feed dog appropriately, and securely tighten the screw (3) in the feed dog.

### 13. NEEDLE-TO-HOOK RELATIONSHIP (Fig.17)

- Set the feed regulating dial to "3".
- Turn the handwheel to bring the needle bar to the lowest position of its stroke, and loosen needle bar connection screw (1).
- Determine the height of the needle bar: The standard height of the needle bar is obtained when a distance of 1.7mm is provided between the top end of the needle eyelet and blade point (6) of the hook when the needles ascends 2.4mm from the lowest position of its stroke.
- Determine the position of the hook: Loosen screw (3) in the gear cover (2), remove gear cover (2) and loosen screws (4) in the large bevel gear.
- In the state described in 3), loosen screw (5) in the hook driving shaft saddle and move the hook driving shaft saddle to the right or left until a clearance of 0 to 0.05 mm is provided between the blade point of the hook and needle (7) .After the adjustment, securely tighten the screw.
- Then , align the blade point of the hook with the center of the needle, and tighten screw (4) in the gear.

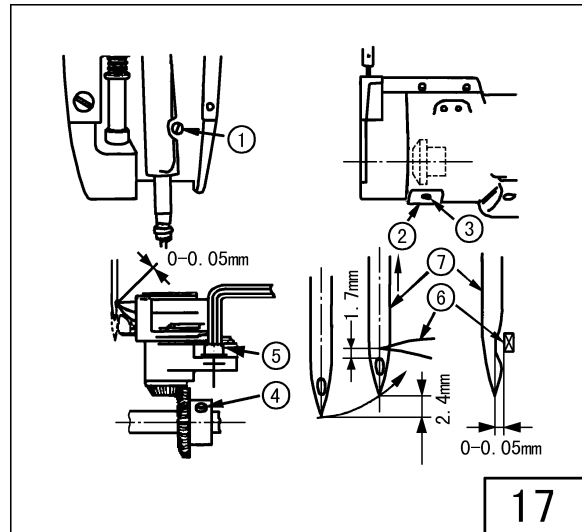

### 14. ADJUSTING THE NEEDLE GUARD OF THE HOOK (Fig.18)

After replacing the hook, be sure to confirm the position of the needle guard. The standard position of the needle guard is obtained when needle guard (2) lightly comes in contact with the side face of needle (1) as illustrated in the figure. If not, adjust the position of the needle guard by bending it accordingly.

- To bend the needle guard inward, apply a screwdriver to the outside of the needle guard.
- To bend the needle guard outward, apply a screwdriver to the needle guard.

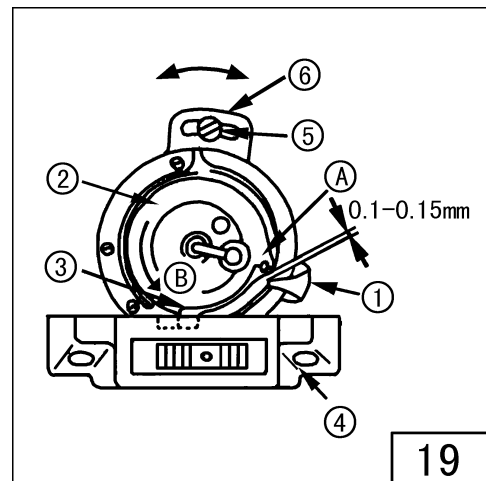
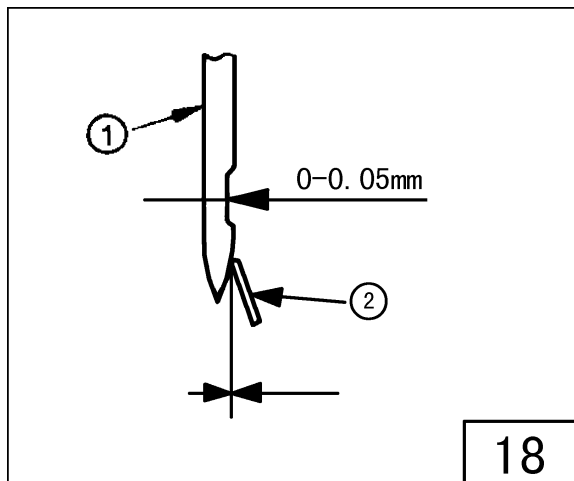



## 15. ADJUSTING THE BOBBIN CASE OPENNING LEVER (Fig.19)

- 1) Turn the hand wheel in its normal rotational direction to bring bobbin case opening lever (1) to its back end position.
- 2) Turn bobbin case (2) in the direction of arrow B until stopper (3) comes in contact with the groove in throat plate (4).
- 3) Loosen screw (5) in the bobbin case opening lever adjustment plate (6) in the direction of the arrow so that a clearance of 0.1 to 0.15 mm is protruding section A of the bobbin case.

## 16. ADJUSTING THE LONGITUDINAL POSITION OF THE NEEDLE BAR FRAME (Fig.20)

- 1) Adjusting the relationship between the top feed rod and presser bar
  - (1) Set the feed regulating dial to its minimum value
  - (2) Loosen clamping screw (1) in the needle bar frame rear arm, and adjust the clearance between the top feed rod and the presser bar to 7.5 mm

**(Caution) Take care not to allow any play in needle bar frame (2)**

- 2) Adjusting the relationship between the feed dog and the needle bar
  - (1) Set the feed regulating dial to its minimum value.
  - (2) Loosen clamping screw (3) in the feed rock shaft crank.
  - (3) Adjust the position of the feed dog so that the needle comes to the center of the needle hole in the feed dog (slightly closer to the operator).

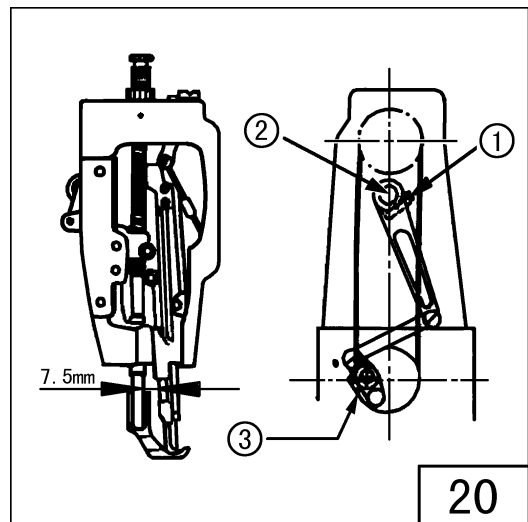

## 17. SAFETY MECHANISM (Fig.21)

If the thread is caught in the hook while the sewing machine is in operation, the safety mechanism actuates to idle the lower sprocket only. If the thread is caught in the hook while the sewing machine is in operation, the safety mechanism actuates to idle the lower sprocket only.

- 1) How to reset
  - (1) Remove the thread caught in the hook
  - (2) Pressing push button (1), strongly turn the pulley in the direction opposite to its normal rotational direction.
- 2) Safety load  
Turn adjustment screw (2) in direction A (clockwise) to increase the safety load, or in direction B (counter-clockwise) to decrease it.

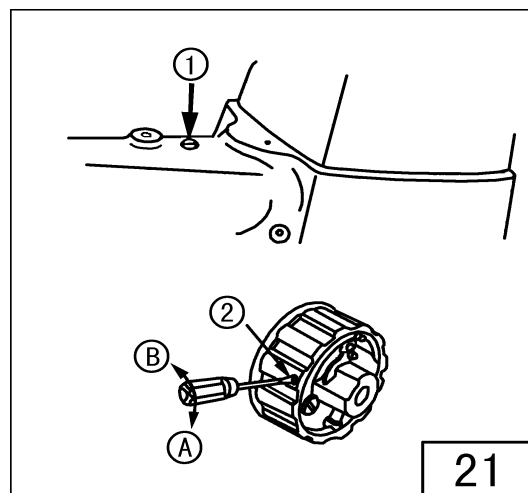

## 18. REPLACING THE TIMING BELT (Fig.22)

### 1) How to remove the timing belt

- (1) Loosen screw ① in the hand wheel, screws ②, in main shaft rear bushing ③, clamping screws ④ in the feed lever shaft arm.
- (2) Remove hand wheel ⑥, and pull out main shaft rear bushing ③.
- (3) Draw feed lever shaft ⑤ until a clearance enough to allow timing belt ⑦ to come off is provided.
- (4) Remove the timing belt from the lower sprocket, draw it from the side window and pull out it from the hole in the main shaft rear bushing.

### 2) How to install the timing belt.

(1) Installation is carried out analogously in reverse order

- (2) The synchronization of the upper shaft and the lower shaft should be guaranteed when assembling the toothed belt. When rotating the belt pulley, make the thread take-up lever on the upper point and then adjust the arrow on the belt pulley bushing ⑧ to the water level position, the belt should be assembled just follow the picture shows.

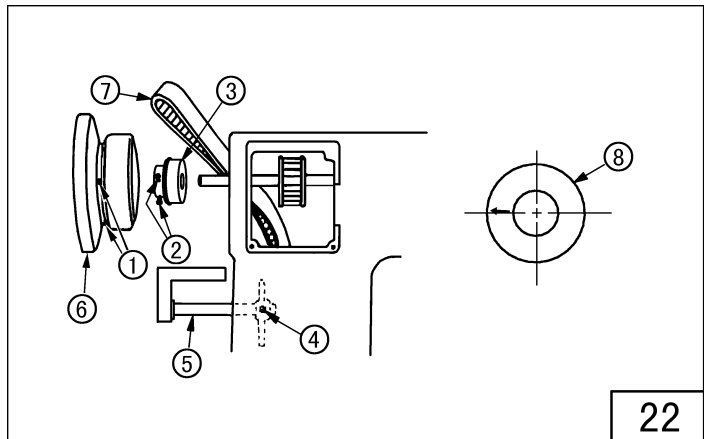

## 19. INSTALLATION OF PRESSER FOOT LIFTER SETTING

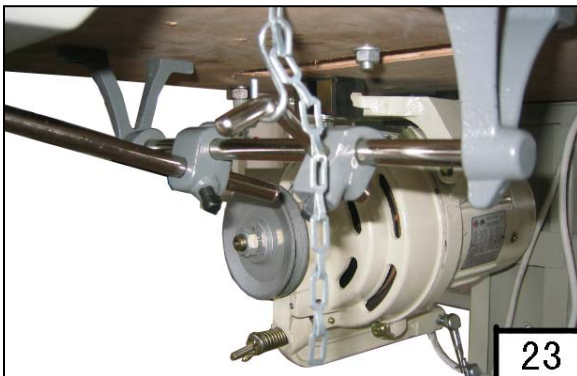

- 1) When using the pedal, fix the presser foot lifter according fig.23 and fig.24.
- 2) When using the knee lifter, fix the presser foot lifter according fig.25.

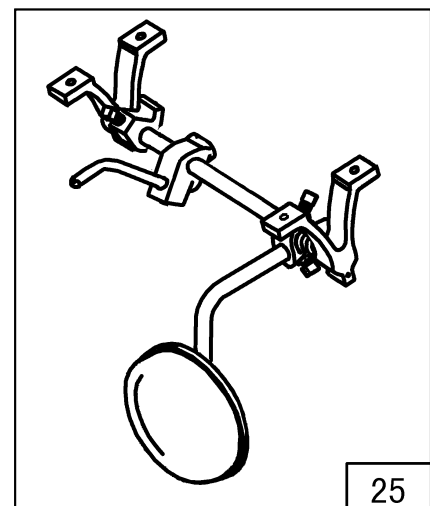

# A.ARM BED AND ITS ACCESSORIES

---

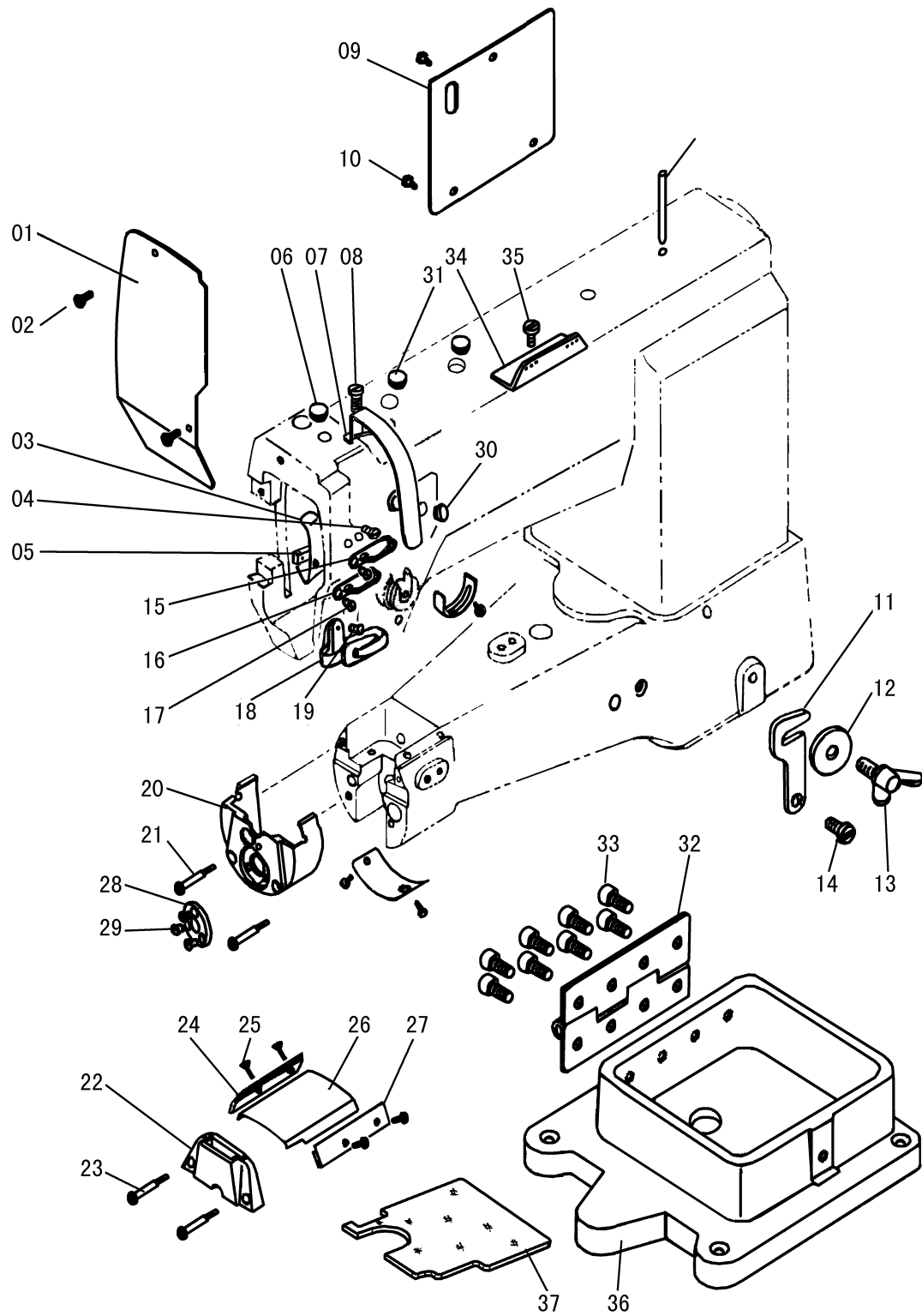

## A.ARM BED AND ITS ACCESSORIES

Fig. No.	Part No.	Description	Pcs.	Remarks
A01	HG209B8001	Side plate	1	
A02	H3100F2360	Screw	2	9/64 (40) × 7
A03	H5335D8001	Oil guard plate	1	
A04	HA7311CH06	Screw	2	9/64 (40) × 8
A05	H2400B2060	Spacer	1	
A06	HA307B0674	Rubber plug	1	φ 11. 8
A07	H4717B8001	Thread take-up lever cover	1	
A08	HA800F2020	Screw	2	15/64 (28) × 13. 5
A09	H5316B8001	Side plate	1	
A10	HA107H1013	Screw	3	11/64 (40) × 6. 5
A11	H4100B2060	Hook	1	
A12	H4100B2090	Washer	1	
A13	H4100B2080	Wing bolt	1	1/4 (24) × 20
A14	H4100B2070	Hinge screw	1	1/4 (24) × 5. 7
A15	H2400B2070	Frame thread guide upper	1	
A16	H4726B8001	Frame thread guide middle	1	
A17	H2400B2080	Screw	2	3/16 (28) × 13
A18	H3212B0066	Thread guide	1	
A19	H3200B2100	Screw	1	9/64 (40) × 6. 5
A20	HG210B8001	Throat plate base frame	1	
A21	H5333B8001	Screw	2	11/64 (40) × 18
A22	H5340B8001	Throat plate	1	
A23	H5341B8001	Screw	2	11/64 (40) × 15
A24	H5337B8001	Bed slide side plate left	1	
A25	H5339B8001	Screw	4	9/64 (40) × 4
A26	H5334B7101	Bed slide	1	
A27	H5338B8001	Bed slide side plate right	1	
A28	H5331B8001	Lower shaft front metal	1	
A29	H5332B8001	Screw	3	11/64 (40) × 4
A30	H2000B2010	Rubber plug	1	φ 13
A31	HA307B0673	Rubber plug	3	φ 19
A32	H5350B7101	Hinge	1	
A33	H415080160	Screw	8	GB/T70. 1 M8 × 16
A34	H2400B2100	Thread guide	1	
A35	HA700B2060	Screw	2	11/64 (40) × 8
A36	H5311B8001	Machine bast	1	
A37	H5354B8001	Felt	1	

## B. THREAD TENSION REGULATOR MECHANISM

---

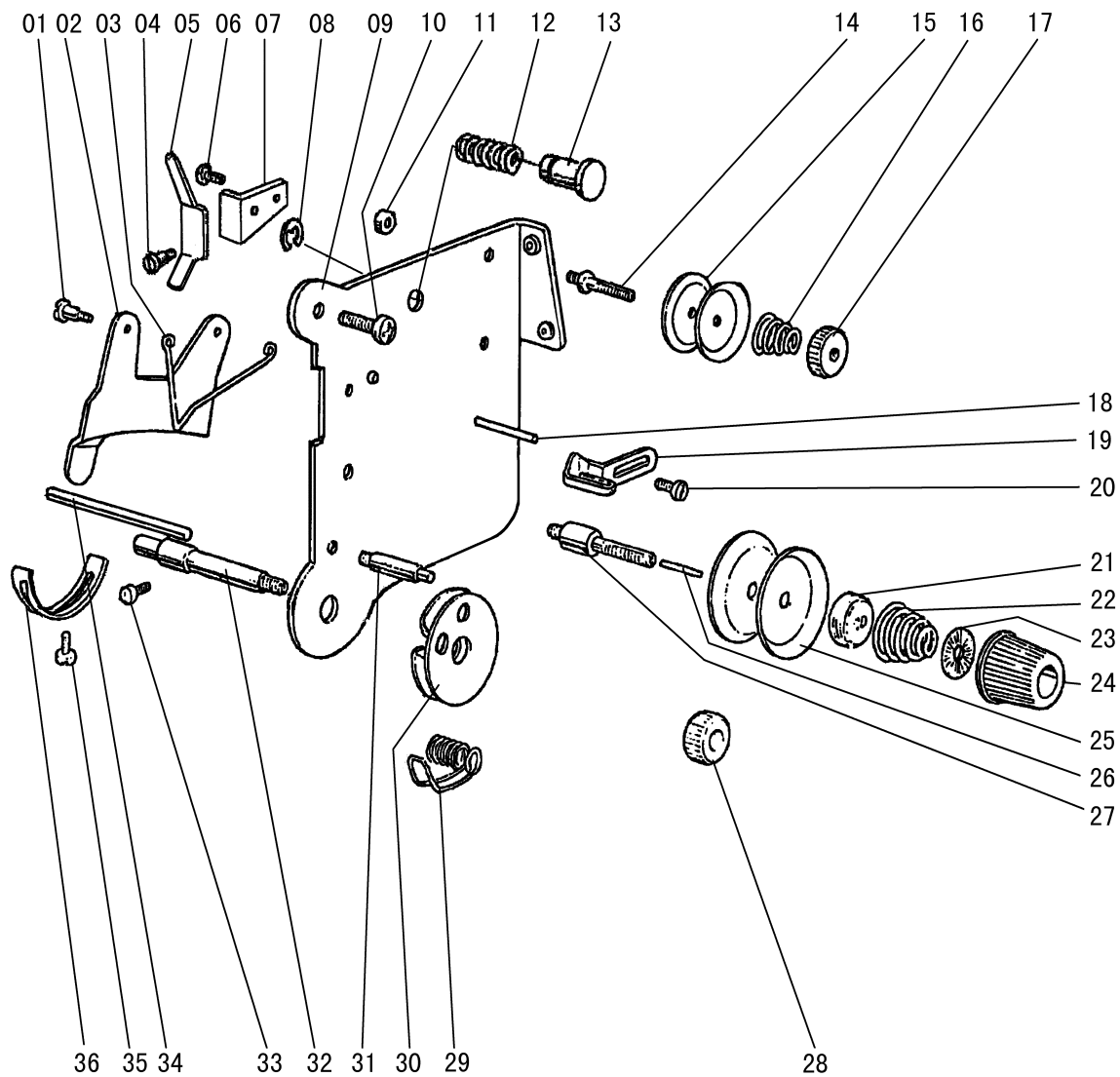

## B.THREAD TENSION REGULATOR MECHANISM

Fig. No.	Part No.	Description	Pcs.	Remarks
B01	H2504C6510	Screw	2	9/64 (40) × 3
B02	H3221B3142	Tension releasing plate	1	
B03	H3221B6812	Tension releasing spring	1	
B04	H4705C8001	Screw	1	
B05	H4706C8001	Lever	1	
B06	HA7311C306	Screw	1	9/64 (40) × 5. 5
B07	H4707C8001	Mounting plate	1	
B08	H007013050	E-type ring	1	
B09	H3221B6820	Mounting plate	1	
B10	HA300C2030	Screw	1	11/64 (40) × 8
B11	H3221B6810	Nut	2	
B12	H4708C8001	Spring	1	
B13	H4709C8001	Push button	1	
B14	H3221B0683	Thread tension stud	1	11/64 (40) × 14
B15	HA112B0693	Thread tension disc	2	
B16	H3300B2040	Spring	1	
B17	HA710B0671	Thumb nut	1	
B18	H3221B0682	Pin	2	
B19	HA106B0676	Screw	1	9/64 (40) × 6
B20	H3306B0661	Thread guide	1	
B21	HA310B0702	Tension releasing disc	1	
B22	H4710C8001	Spring	1	
B23	HA115B7010	Thumb nut revolution stopper	1	
B24	HA310B0701	Thumb nut	1	
B25	HA310B0705	Thread tension disc	2	
B26	H3221B0686	Thread tension stud	1	1/4 (40) × 23
B27	H32481B721	Thumb nut	1	
B28	H4713C8001	Thread take-up spring	1	
B29	H32481BD21	Plate complete	1	
B30	H4804C8001	Thread tension stud	1	9/64 (40) × 9
B31	H4805C8001	Thread tension stud	1	1/4 (40) × 14. 5
B32	H3230K0751	Screw	1	11/64 (40) × 10
B33	H3221B6817	Pin	1	
B34	HG204C8001	Pin	1	
B35	H3200B2100	Screw	1	9/64 (40) × 6. 5
B36	H3221B6819	Stopper	1	

# C.TAKE-UP THREAD AND ARM SHAFT MECHANISM

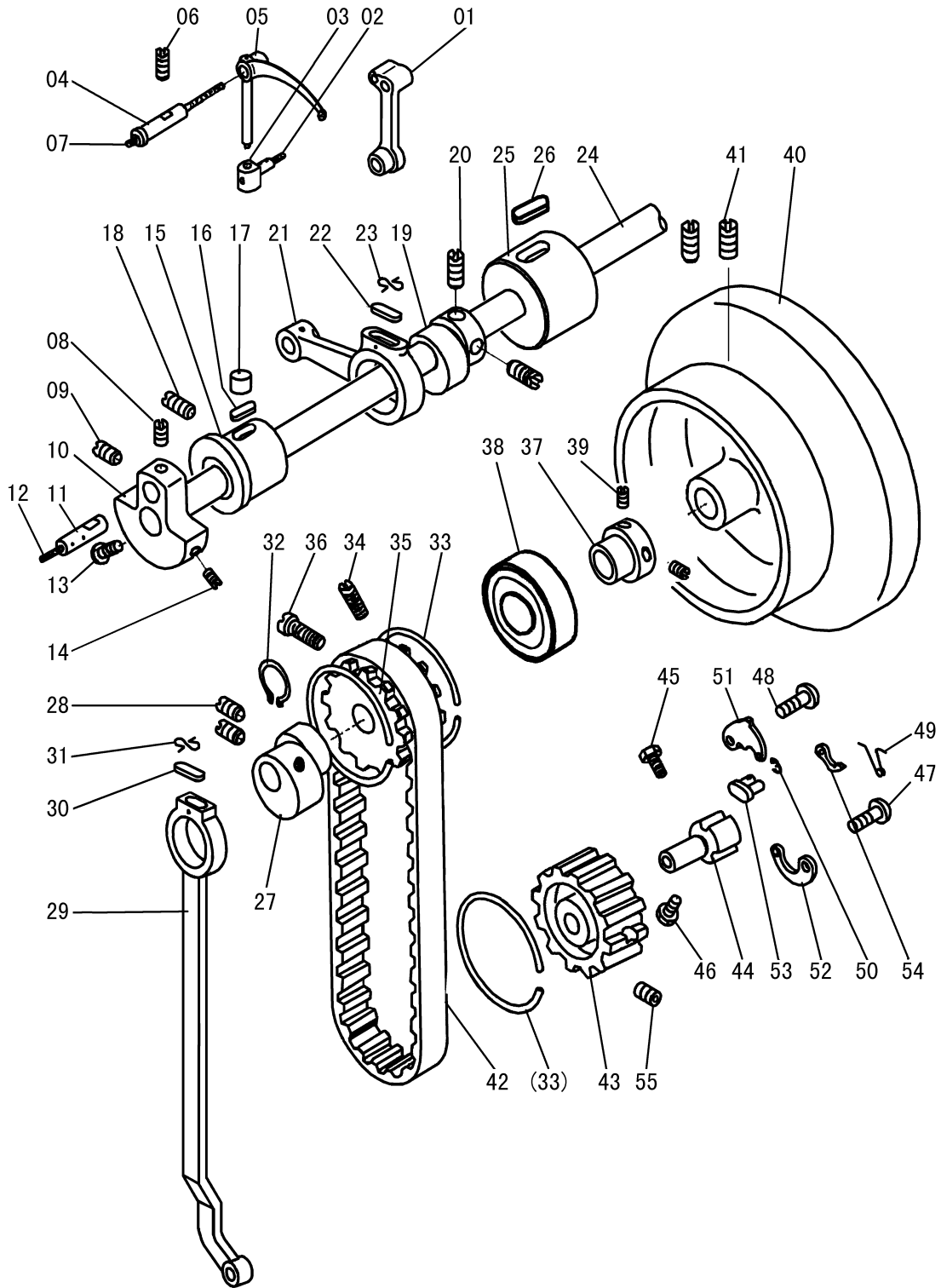

## C.TAKE-UP THREAD AND ARM SHAFT MECHANISM

Fig. No.	Part No.	Description	Pcs.	Remarks
C01	H3100C2060	Needle bar connecting link	1	
C02	H3100C2050	Oil wick	1	
C03	H3100C2040	Thread take-up link	1	
C04	H0209F8001	Pin	1	
C05	H5305C8001	Thread take-up lever	1	
C06	HA100C2020	Set screw	1	15/64 (28) × 10
C07	H5306C8001	Holder	1	
C08	HA105D0662	Screw	1	1/4 (40) × 4
C09	HA307C0662	Screw	1	1/4 (40) × 6
C10	H5310C8001	Needle bar crank	1	
C11	H5311C8001	Pin	1	
C12	H2405D0663	Oil wick	1	
C13	HA100C2060	Screw	1	9/32 (28) × 13
C14	HA100C2070	Screw	1	9/32 (28) × 10
C15	H5315C8001	Arm shaft bushing (left)	1	
C16	H5316C8001	Felt	1	
C17	H5317C8001	Felt	1	
C18	HA100C2020	Screw	1	15/64 (28) × 10
C19	HG204D8001	Feed cam (left)	1	
C20	HA307C0662	Screw	2	1/4 (40) × 6
C21	HG205D8001	Upper feed driving rod	1	
C22	H2014J0068	Oil felt	1	
C23	H2000C2030	Felt retainer	1	
C24	H5314C8001	Arm shaft	1	
C25	H5326C8001	Arm shaft bushing (middle)	1	
C26	H5327C8001	Felt	1	
C27	H5332C8001	Feed cam (right)	1	
C28	HA307C0662	Screw	2	1/4 (40) × 6
C29	H5329C8001	Connecting rod for upper feed	1	
C30	H5330C8001	Felt	1	
C31	H20111C106	Holder	1	
C32	H007010260	Stop ring	1	
C33	H3205C0661	Spring stop ring	2	
C33	H3205C0661	Stop ring	1	
C34	HA113F0684	Screw	1	15/64 (28) × 8.5
C35	H5337C8001	Pulley (upper)	1	
C36	HA100F2130	Screw	1	15/64 (28) × 8
C37	H5336C8001	Arm shaft bushing (right)	1	
C38	H3208H0661	Needle bearing	1	6004ZZNR/5K
C39	HA113F0684	Screw	2	15/64 (28) × 8.5
C40	H4100C2040	Balance wheel	1	
C41	HA110D0672	Screw	2	15/64 (28) × 12
C42	H5338C8001	Cog belt	1	



## C.TAKE-UP THREAD AND ARM SHAFT MECHANISM

Fig. No.	Part No.	Description	Pcs.	Remarks
C43	H5334D8001	Pulley	1	
C44	H5333D8001	Shaft for pulley	1	
C45	HA104F0654	Screw	1	15/64(28)×10
C46	H4721D8001	Screw	1	15/64(28)×8.5
C47	H4714D8001	Pin	1	
C48	H4718D8001	Pin	1	
C49	H4716D8001	Spring for pulley	1	
C50	H007013025	E-type stop ring	1	GB/T896 2.5
C51	H4719D8001	Short lever for pulley	1	
C52	H4713D8001	Long lever for pulley	1	
C53	H4715D8001	Pin	1	
C54	H4717D8001	Lever for pulley	1	
C55	H4723D8001	Screw	2	15/64(28)×4.5

# D.NEEDLE BAR AND ROTATING HOOK SHAFT MECHANISM

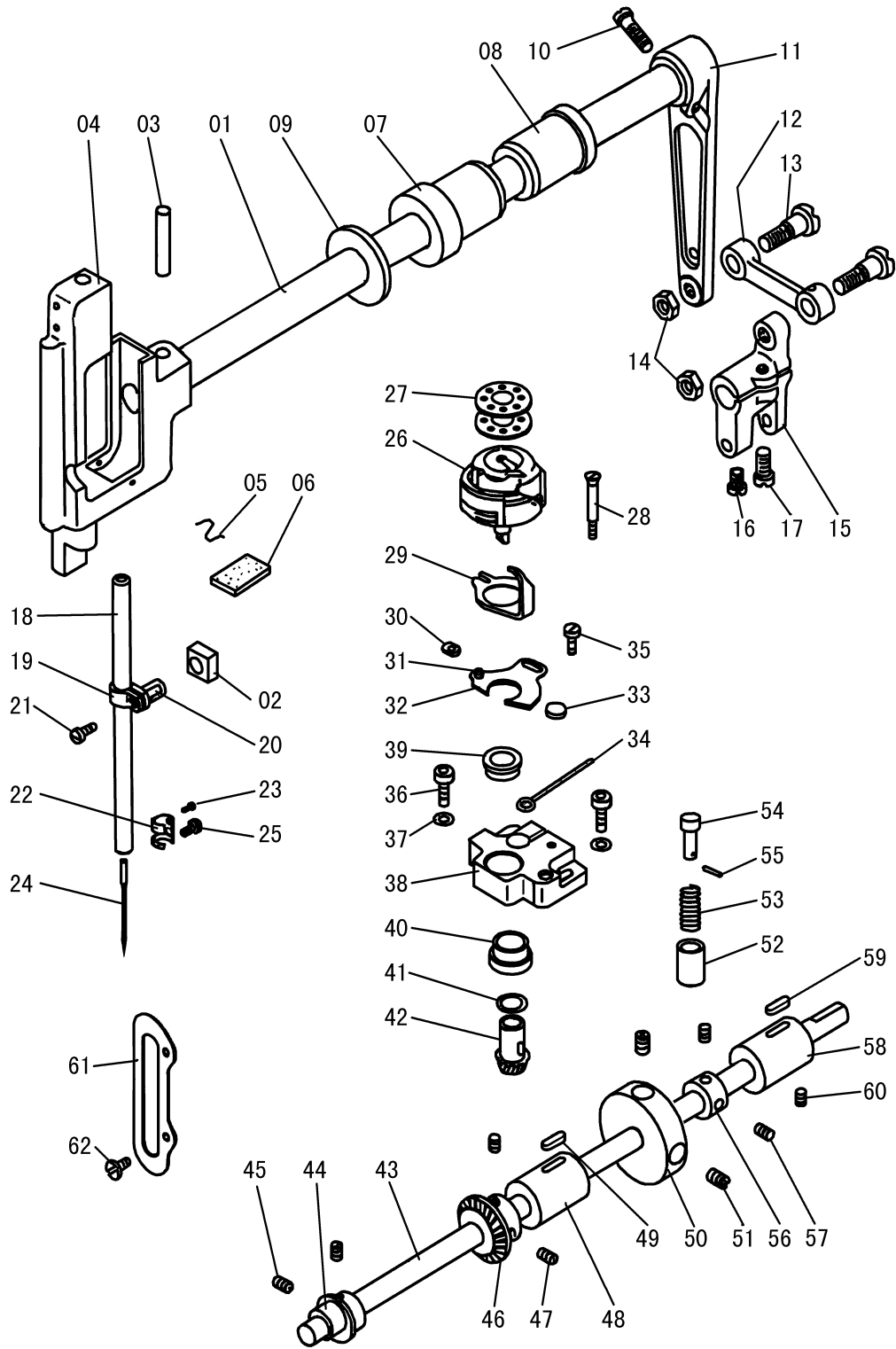

## D.NEEDLE BAR AND ROTATING HOOK SHAFT MECHANISM

Fig. No.	Part No.	Description	Pcs.	Remarks
D01	H5325F8001	Needle bar rock shaft	1	
D02	H5324F8001	Slide block	1	
D03	H602040260	Pin	1	A4×26
D04	H5316F8001	Needle bar rock frame	1	
D05	H5319F8001	Felt	1	
D06	H5320F8001	Felt clip	1	
D07	H5328F8001	Needle bar rock shaft bushing (right)	1	
D08	H5327F8001	Needle bar rock shaft bushing (left)	1	
D09	H5326F8001	Washer	1	
D10	H5320H8001	Screw	1	15/64(28)×23.5
D11	H5319H8001	Link	1	
D12	H5316H8001	Link	1	
D13	H5317H8001	Screw	2	9/32(28)×13.3
D14	H2010J0066	Nut	2	9/32(28)×3.6
D15	H5314H8001	Crank	1	
D16	HA700F2100	Screw	1	11/64(40)×10
D17	HA800F2020	Screw	1	15/64(28)×13.5
D18	H3129F0692	Needle bar	1	
D19	H4722F8001	Needle bar connecting stud	1	
D20	H3204D6513	Felt	1	
D21	HA7311CD06	Screw	1	9/64(40)×8.5
D22	H5322F8001	Thread guide for needle bar	1	
D23	H3129F0691	Screw	1	3/32(56)×2.5
D24	H4740F8001	Needle	1	DP×17 #23
D25	HA100C2170	Screw	1	1/8(44)×4.5
D26	H5320D7101	Rotating hook	1	KRT341NR
D27	H1100E2010	Bobbin	1	BO-PF541
D28	H5337D8001	Screw	1	9/64(40)×10
D29	H5323D8001	Rotating position guide	1	
D30	H41622D216	Guide plate slide block	1	
D31	H410268D16	Guide plate pin	1	
D32	H5329D8001	Guide plate	1	
D33	H5326D8001	Felt	1	
D34	H5327D8001	Oil wick	1	
D35	H2204C0651	Screw	1	9/64(40)×5
D36	H425050120	Screw	2	M5×12
D37	H005004050	Washer	2	
D38	H5325D8001	Rotating hook bracket	1	
D39	HG208E8001	Bushing	1	
D40	HG209E8001	Bushing	1	
D41	HG210E8001	Washer	1	
D42	HG211E8001	Bevel gear for hook shaft	1	
D43	H5304D8001	Rotating hook shaft	1	

## D.NEEDLE BAR AND ROTATING HOOK SHAFT MECHANISM

Fig. No.	Part No.	Description	Pcs.	Remarks
D44	H5306E8001	Feed eccentric	1	
D45	HA305E0662	Set screw	2	15/64(28)×4.5
D46	HG212E8001	Bevel gear for hook shaft	1	
D47	HA108C0663	Set screw	3	1/4(40)×7
D48	H5315D8001	Rotating hook shaft bushing (left)	1	
D49	H5316D8001	Oil wick		
D50	H5308D8001	Recessed wheel	1	
D51	HA3411D308	Set screw	2	15/64(28)×7
D52	H4107D0671	Safe clutch bushing	1	
D53	H4107D0672	Safe clutch spring	1	
D54	H5309D8001	Safe clutch shaft	1	
D55	H609020120	Safe clutch shaft pin	1	A2×12
D56	HG206E8001	Rotating hook shaft collar	1	
D57	HE051C8001	Screw	2	SM1/4"(40)×5.5
D58	HG205E8001	Rotating hook shaft bushing (right)	1	
D59	H5319D8001	Oil wick		
D60	HA3411D308	Screw	1	15/64(28)×7
D61	H5314F8001	Guide for slide block	1	
D62	HA700F2100	Screw	2	11/64(40)×7

# E.PRESSER FOOT FEEDING MECHANISM

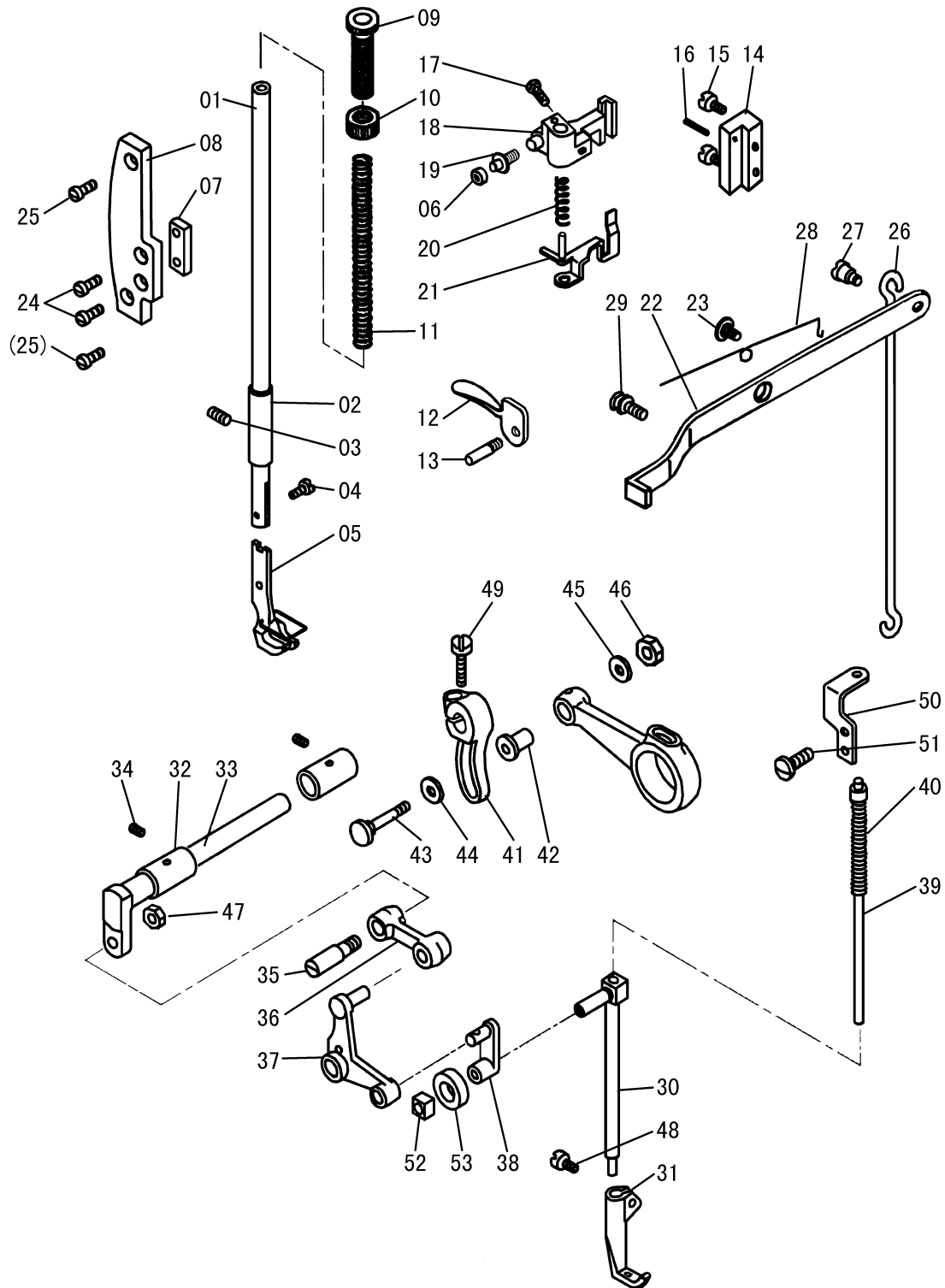

## E.PRESSER FOOT FEEDING MECHANISM

Fig. No.	Part No.	Description	Pcs.	Remarks
E01	H4754E8001	Presser bar	1	
E02	HG204F8001	Presser bar lower bushing	1	
E03	HA100C2020	Screw	1	15/64(28)×10
E04	H3200E2020	Screw	1	1/8(44)×4
E05	H5331G8001	Presser foot aecy	1	
E06	H2000J2030	Connecting pim roller	1	
E07	HG211F8001	Presser bar bracket guide	1	
E08	HG205F8001	Guide plate base	1	
E09	H2400G2140	Presser spring regulator	1	
E10	HA117H0692	Nut	1	1/2(28)
E11	HG206F8001	Presser spring	1	
E12	H3100G2070	Hand lifter	1	
E13	HG207F8001	Hand lifter pin	1	
E14	H3100G2210	Lifting bracket guide block	1	
E15	HE040D8001	Screw	1	17/64(24)×17.5
E16	H609025180	Pin	1	
E17	H3107G0661	Screw	1	11/64(40)×14
E18	HG208F8001	Presser lifting lever base	1	插图31H6-004B3
E19	H2004J0655	Guide shaft hinge screw	1	3/16(28)
E20	H3100G2050	Thread release spring	1	
E21	H3109G0651	Thread release guide assy	1	
E22	HG209F8001	Presser bar lifting lever	1	
E23	H3100G2130	Hinge screw	1	1/4(24)×7
E24	HA100C2190	Screw	2	11/64(40)×8
E25	HG210F8001	Screw	2	15/64(28)×10
E26	H5318G8001	Hanging rod	1	
E27	H5314G8001	Screw	1	3/16(28)×4.5
E28	H4727E8001	Twist spring	1	
E29	HG212F8001	Screw	1	
E30	H3100F2070	Walking bar	1	
E31	H5331F8001	Walking foot	1	
E32	H3100F2100	Bushing	2	
E33	H3112F0663	Upper feed driving shaft	1	
E34	HA100B2110	Screw	2	11/64(40)×5.5
E35	H3112F0661	Screw stud	1	1/4(28)
E36	H3100F2010	Upper feed dconnecting link	1	
E37	H3100F2020	L shaped link	1	
E38	H3100F2030	Walking bar driving link	1	
E39	H5332F7101	Walking bar spring	1	
E40	H2000J2120	Walking bar spring	1	
E41	H3115F0672	Upper feed spring rod	1	
E42	H3100F2150	Connecting stud	1	
E43	H3100F2130	Hinge screw	1	7/32(32)

## E.PRESSER FOOT FEEDING MECHANISM

Fig. No.	Part No.	Description	Pcs.	Remarks
E44	HE045D8001	Washer	1	
E45	H4728H8001	Washer	1	
E46	H3100F2160	Nut	1	7/32(32)
E47	H3112F0662	Nut	1	1/4(28)
E48	HA100C2040	Screw	1	11/64(40)×5.5
E49	H3115F0671	Screw	1	1/4(28)×16
E50	H5334F8001	Walking bar retaining plate	1	
E51	H2004J0067	Screw	2	9/64(40)×7
E52	H5315F8001	Walking bar guide roller	1	
E53	HG213F8001	Felt	1	

# F.STITCH REGULATOR MECHANISM

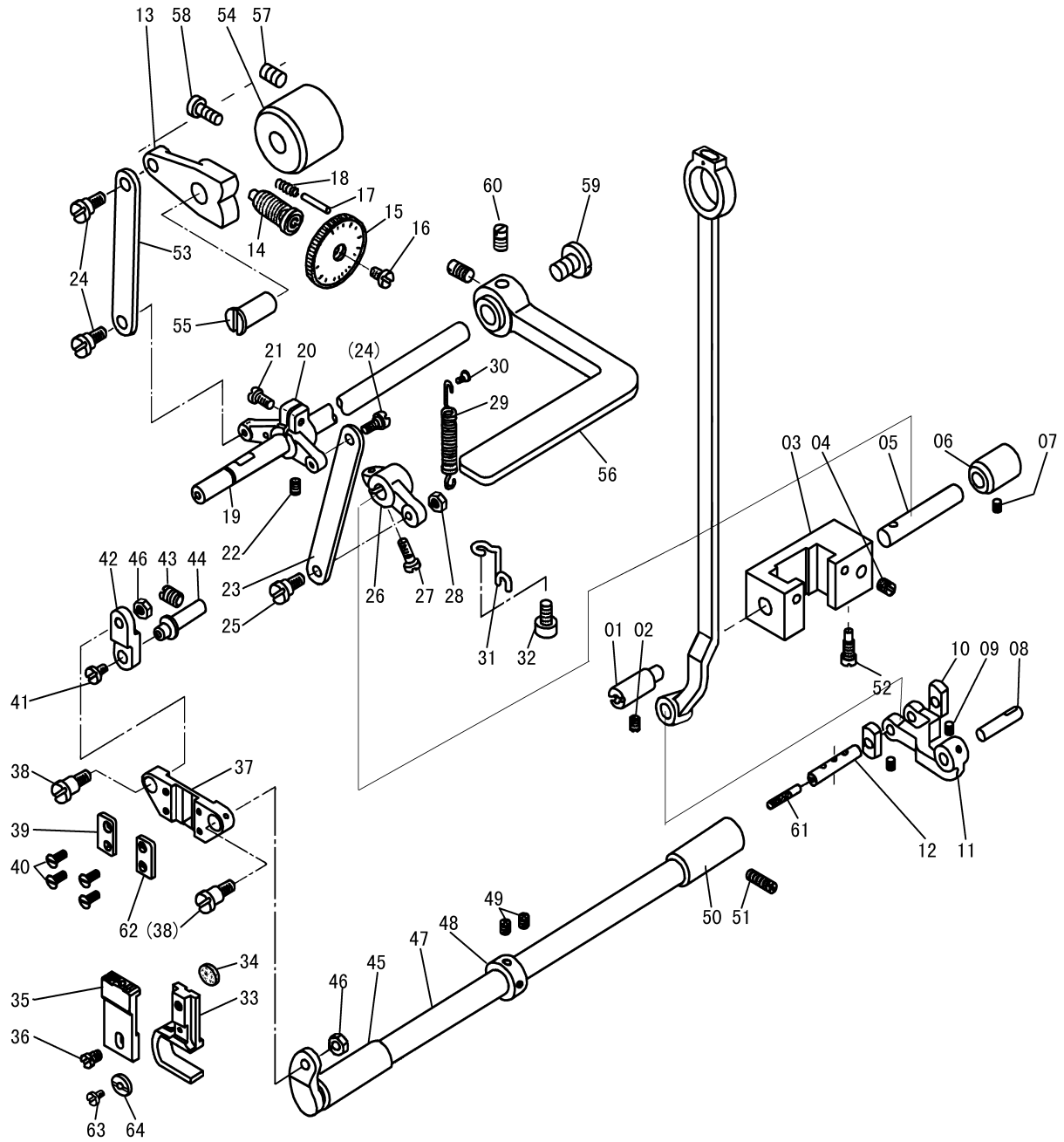



## F.STITCH REGULATOR MECHANISM

Fig. No.	Part No.	Description	Pcs.	Remarks
F01	H5308H8001	Feed driving rocker hinge pin	1	
F02	HA100C2020	Screw	1	15/64(28)×10
F03	H5305H8001	Feed driving rocker	1	
F04	HA100F2130	Screw	1	15/64(28)
F05	H5306H8001	Feed driving rocker shaft	1	
F06	H5307H8001	Bushing	1	
F07	HA3411D308	Screw	1	15/64(28)×7
F08	H5315H8001	Feed rocker shaft crank pin	1	
F09	HA711B0681	Screw	2	9/64(40)×4.5
F10	H5309H8001	Slide block	2	
F11	H5313H8001	Feed driving rocker arm	1	
F12	H5311H8001	Slide block shaft	1	
F13	H5334H8001	Feed regulator	1	
F14	HA720F0681	Needle feed regulating spring	1	
F15	HA7421F120	Stitch dial assy	1	
F16	HA720F0686	Screw	1	3/16(28)×12
F17	HA700F2030	Pin	1	
F18	HA100F2090	Spring	1	
F19	H5339H8001	Reverse feed lever shaft	1	
F20	H5327H8001	Control lever crank	1	
F21	H5343H8001	Screw	1	3/64(32)×16
F22	HA3411D308	Screw	1	15/64(28)×7
F23	H5323H8001	Control lever crank link A	1	
F24	H5333H8001	Hinge screw	3	3/16(32)×8.5
F25	H5324H8001	Hinge screw	1	3/16(32)×13.5
F26	H5322H8001	Feed driving rocker shaft arm	1	
F27	HA104G0012	Screw	1	3/16(28)×12
F28	H5325H8001	Nut	1	3/16(32)
F29	HG207G8001	Tension spring	1	
F30	H5329H8001	Hinge screw	1	9/64(40)×4
F31	H5330H8001	Suspension hook	1	
F32	H2000I2050	Screw	1	9/64(40)×8
F33	HG205G8001	Feed bar crank	1	
F34	H41111E204	Oil felt	1	
F35	H5304E8001	Feed dog	1	
F36	HA700F2100	Screw	1	11/64(40)×7
F37	H5307E8001	Feed bar support	1	
F38	H5315E8001	Hinge screw	2	1/4(40)×9
F39	H5308E8001	Feed bar support plate	1	
F40	H5309E8001	Screw	4	1/8(44)×6.3
F41	H5314E8001	Screw	1	11/64(40)×7.5
F42	H5312E8001	Feed bar link	1	
F43	HA100C2020	Screw	1	15/64(28)×10

## F.STITCH REGULATOR MECHANISM

Fig. No.	Part No.	Description	Pcs.	Remarks
F44	H5313E8001	Feed rocker link shaft	1	
F45	H5320E8001	Bushing front	1	
F46	H5316E8001	Nut	2	1/4 (40)
F47	H5317E8001	Feed rocker shaft	1	
F48	H5319E8001	Thrust coolar	1	
F49	H6039G8001	Screw	2	11/64(40)×3.8
F50	H5321E8001	Bushing rear	1	
F51	HA100C2020	Screw	1	15/64(28)×10
F52	HA100F2130	Screw	1	15/64(28)
F53	H5332H8001	Feed lever connecting link B	1	
F54	H5338H8001	Feed regulator bushing	1	
F55	H5335H8001	Hinge pin	1	
F56	H5342H8001	Feed lever	1	
F57	HA3411D308	Screw	1	15/64(28)×7
F58	H5336H8001	Screw	1	15/64(28)×14.3
F59	HA113F0683	Screw	1	3/16(28)×6.5
F60	HA113F0684	Screw	2	15/64(28)×8.5
F61	H5312H8001	Oil wick	1	
F62	H5310E8001	Feed bar support	1	
F63	HE114E8001	Screw	1	11/64(40)×4
F64	HE115E8001	Stop ring	1	

# G.ACCESSORIES

---

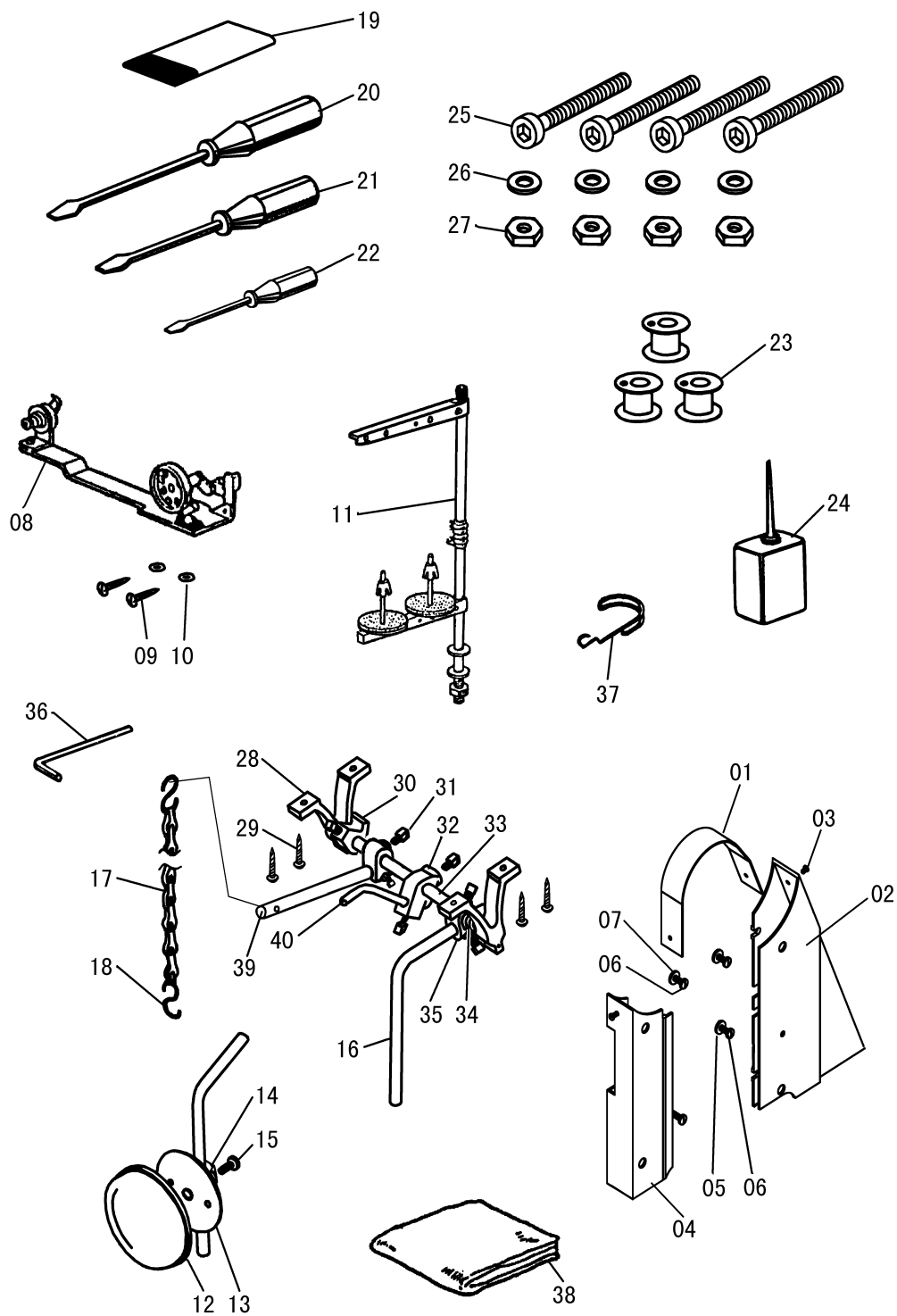

## G.ACCESSORIES

Fig. No.	Part No.	Description	Pcs.	Remarks
G01	H6307L8001	Belt cover (upper)	1	
G02	H5311I8001	Belt cover (right)	1	
G03	H2000O0360	Screw	2	11/64(40)×6
G04	H5312I8001	Belt cover (left)	1	
G05	H6722N8001	Washer	1	
G06	H0207L8001	Screw	4	15/64(28)×8
G07	H0206L8001	Washer	2	
G08	HA706S0067	Bobbin winder assy	1	
G09	H801045200	Wood screw	2	4.5×20
G10	HA300J2230	Washer	2	5
G11	HA200J2030	Thread stand assy	1	
G12	HA106J0668	Knee lifter cover	1	
G13	HA106J0665	Knee lifter plate	1	
G14	HA106J0666	Knee lifter bracket	1	
G15	HA106J0667	Screw	1	
G16	HA106J0662	Knee lifter shaft	1	
G17	HPG100E203	Chain	1	
G18	HPG100E202	S shaped hook	2	
G19	H4740F8001	Needle	2	DP×17 23#
G20	HA300J2070	Screw driver (large)	1	
G21	HA300J2200	Screw driver (middle)	1	
G22	HA300J2210	Screw driver (small)	1	
G23	H1100E2010	Bobbin	2	
G24	H2004O0069	Oil assy	1	
G25	H403080750	Screw	4	M8×75
G26	H005001080	Washer	4	
G27	H003002080	Nut	4	M8
G28	H2015O0065	Knee lifter	2	
G29	H802045250	Wood screw	4	4.5×25
G30	H2015O0067	Set blore	1	
G31	HA300J2180	Screw	5	
G32	H2015O0069	Knee lifter shaft	1	
G33	H2015O0066	Knee lifter shaft	1	
G34	H2016O0070	Coil spring	1	
G35	H5313I8001	Connector	1	
G36	HB00001060	Socket wrench	1	6mm
G37	HE204I8001	Finger gusrd	1	
G38	HA100J2180	Vinyl cover	1	
G39	HG208H8001	Lever	1	
G40	H3104H0651	Knee lifter shaft	1	

**SHANGHAI BIAOZHUN HAILING SEWING MACHINERY CO., LTD.**

**ADD: NO.850 Shulin Road, Songjiang District Shanghai, P.R.China**

**Zip Code: 201612**

**Overseas Business: TEL: 86-21-64853303 FAX: 86-21-64854304**

**E-mail:sales@highlead.com.cn      <http://www.highlead.com.cn>**

The description covered in this manual is subject to change for improvement of the commodity without notice

2016.7. Printed