



GC2268-2BXL

长臂型筒式双针综合送料平缝机

零件样本

上海标准海菱缝制机械有限公司
SHANGHAI BIAOZHUN HAILING SEWING MACHINERY CO., LTD.

A. 机壳部件

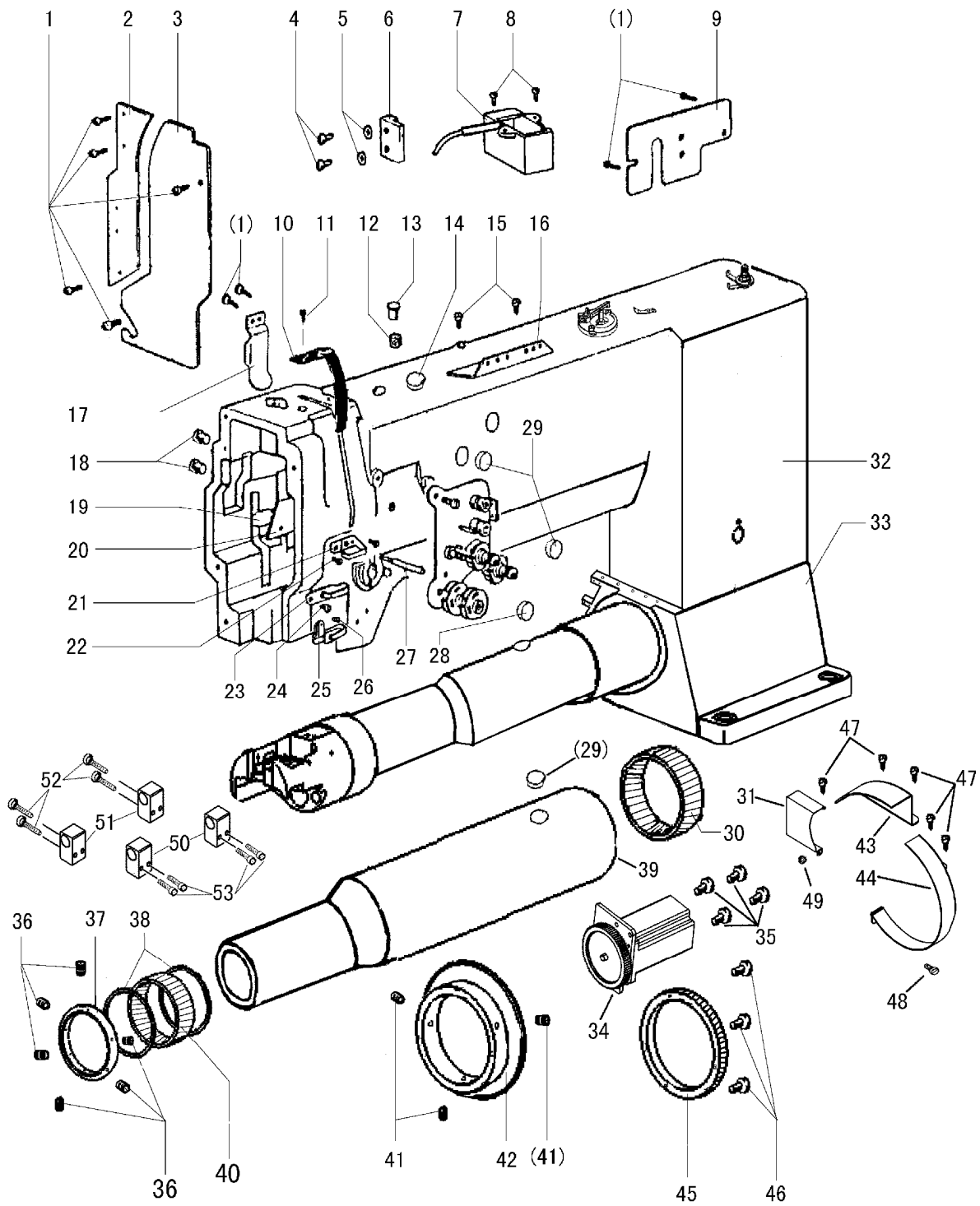

A. 机壳部件

序号	样本编号	名 称	件数	备 注
A01	HA300B2170	盖板螺钉	9	SM11/64(40)×9
A02	H4730B8001	滑块导轨安装板	1	
A03	H4727B8001	面板	1	
A04	HA100E2150	导轨安装螺钉	2	SM11/64(40)×10
A05	H4722E8001	垫圈	2	
A06	H4721E8001	滑块导轨	1	
A07	HH61B17101	油盒组件	1	
A08	H411040160	螺钉	2	发黑
A09	H4718B8001	后盖板（左）	1	
A10	H4717B8001	挑线杆防护罩	1	
A11	HA300C2030	挑线杆防护罩螺钉	1	SM11/64(40)×8
A12	H32175B304	羊毛毡	1	
A13	H4715B8001	橡皮塞	1	φ13（机壳顶上）
A14	H4735B8001	橡皮塞	2	φ22（机壳顶上/后面）
A15	HA700B2060	线勾螺钉	2	SM11/64(40)×8
A16	H2400B2100	上过线板	1	
A17	H4716B8001	防油板	1	
A18	HA300B2090	橡皮塞	2	φ8.8（机壳后面）
A19	H2400B2060	挡油罩板垫块	1	
A20	H3200B2060	挡油板	1	
A21	H2400B2070	线勾（上）	1	
A22	H2400B2080	过线勾沉头螺钉	2	SM3/16(28)×13
A23	H4726B8001	线勾（中）	1	
A24	H3000D2160	防油垫固定板螺钉	1	SM9/64(40)×6.5
A25	H3212B0066	线勾（下）组件	1	
A26	H3200B2100	圆柱头螺钉	1	SM9/64(40)×6.5
A27	H7010E8001	挺线销	1	
A28	H4736B8001	橡皮塞	1	φ15（机壳后面）
A29	HA307B0673	橡皮塞	3	
A30	HN23B98001	带保持架滚针套	1	
A31	HN23B58001	罩壳（后）	1	
A32	HN20B68001	车壳	1	
A33	HN20B78001	机座	1	
A34	HN23B17101	电机组件	1	
A35	H415060300	内六角圆柱头螺钉	4	
A36	H7206E8001	挡圈螺钉	6	SM15/64(28)×6
A37	HN21B58001	挡圈	1	
A38	HN21B48001	轴承挡圈	2	
A39	HN24B07101	转筒组件	1	
A40	HN21B38001	滚针轴承	1	K75×83×30
A41	H7206E8001	转盘螺钉	3	SM15/64(28)×6
A42	HN23B08001	转盘	1	
A43	HN23B78001	罩壳（上）	1	

A. 机壳部件

序号	样本编号	名 称	件数	备 注
A44	HN23B68001	罩壳（前）	1	
A45	HN23B38001	齿轮（大）	1	
A46	H3100G2120	齿轮安装螺钉	3	SM9/64(40)×9
A47	HE929D8001	螺钉	5	SM11/64(40)×7.5
A48	H415040100	内六角圆柱头螺钉	1	
A49	H003002040	六角螺母	1	
A50	HN21D48001	送布轴支撑轴套	1	
A51	HN21D38001	下轴支撑轴套	1	
A52	H415040200	内六角圆柱头螺钉	4	
A53	H415040150	内六角圆柱头螺钉	4	

B. 上轴部件

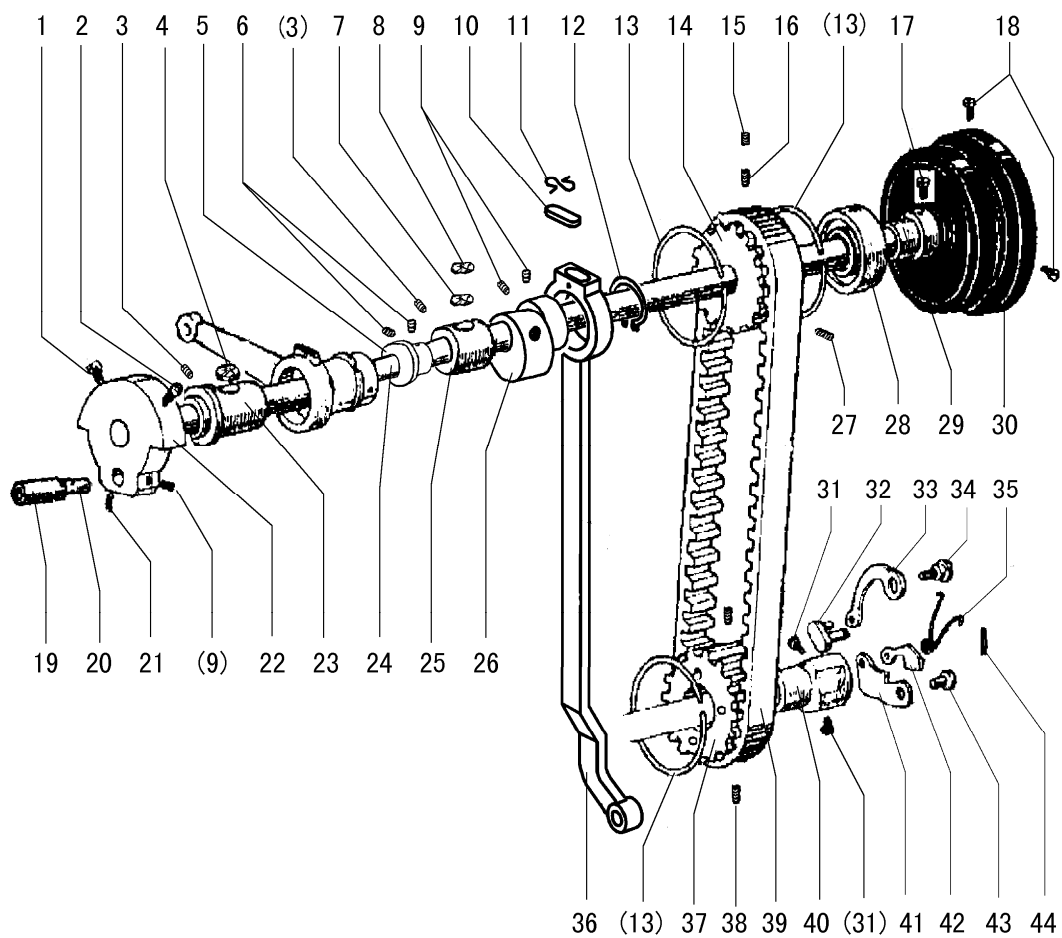

B、上轴部件

序号	样本编号	名 称	件数	备 注
B01	HA100C2060	针杆曲柄螺钉	1	SM9/32(28)×13
B02	HA100C2070	针杆曲柄定位螺钉	1	SM9/32(28)×14
B03	H2405D0664	挑线曲柄定位螺钉	1	SM15/64(28)×14
B04	H32111B104	上轴轴套羊毛毡	1	
B05	H7005D8001	套筒	1	
B06	H4723D8001	套筒螺钉	2	SM15/64(28)×4.5
B07	H6616B8001	羊毛毡	1	
B08	H2009B0731	羊毛毡	1	
B09	HA307C0662	送布凸轮(右)螺钉	3	SM1/4(40)×6
B10	H20111C106	送布连杆羊毛毡夹	1	
B11	H5330C8001	送布连杆羊毛毡	1	
B12	H007009260	轴用弹性挡圈	1	
B13	H3205C0661	弹簧挡圈	3	
B14	HH60C78001	同步带轮(上)	1	
B15	HE030C8001	止动螺钉	1	SM17/64(24)×6.5
B16	HE029C8001	长定位螺钉	1	SM17/64(24)×14.5
B17	HA113F0684	上轴紧圈螺钉	2	SM15/64(28)×8.5
B18	HA110D0672	主动轮螺钉	2	SM15/64(28)×12
B19	H2405D0662	挑线曲柄连杆轴	1	
B20	H4716F8001	连杆轴油线	1	
B21	HA105D0662	上轴紧圈螺钉	1	SM1/4(40)×4
B22	H4706D8001	针杆曲柄	1	
B23	H32111B204	上轴轴套(左)	1	
B24	HN20C58001	上轴	1	
B25	HF126B8001	上轴中间轴套	1	
B26	H5332C8001	送布凸轮(右)	1	
B27	HE028C8001	同步带轮紧定螺钉	1	SM17/64(24)×20
B28	H3205J0662	轴承	1	
B29	H3205J0661	上轴紧圈	1	
B30	H4100C2040	主动轮	1	
B31	HE022G8001	紧定螺钉	2	SM1/4(32)×10.5
B32	HE027G8001	连接销	1	
B33	HE023G8001	长连杆	1	
B34	HE024G8001	长连杆销	1	
B35	HE026G8001	同步带轮弹簧	1	
B36	HH60C58001	送布连杆	1	
B37	HE019G8001	同步带轮(下)	1	
B38	HE028E8001	同步带轮定位螺钉	2	SM7/32(24)×7
B39	HE109C8001	同步带	1	
B40	HE021G8001	同步带轮轴	1	
B41	H4719D8001	短连杆	1	
B42	HE031G8001	同步带轮连杆	1	
B43	HE029G8001	短连杆销	1	
B44	H601012100	挡销	1	

C. 针杆挑线、转筒送料部件

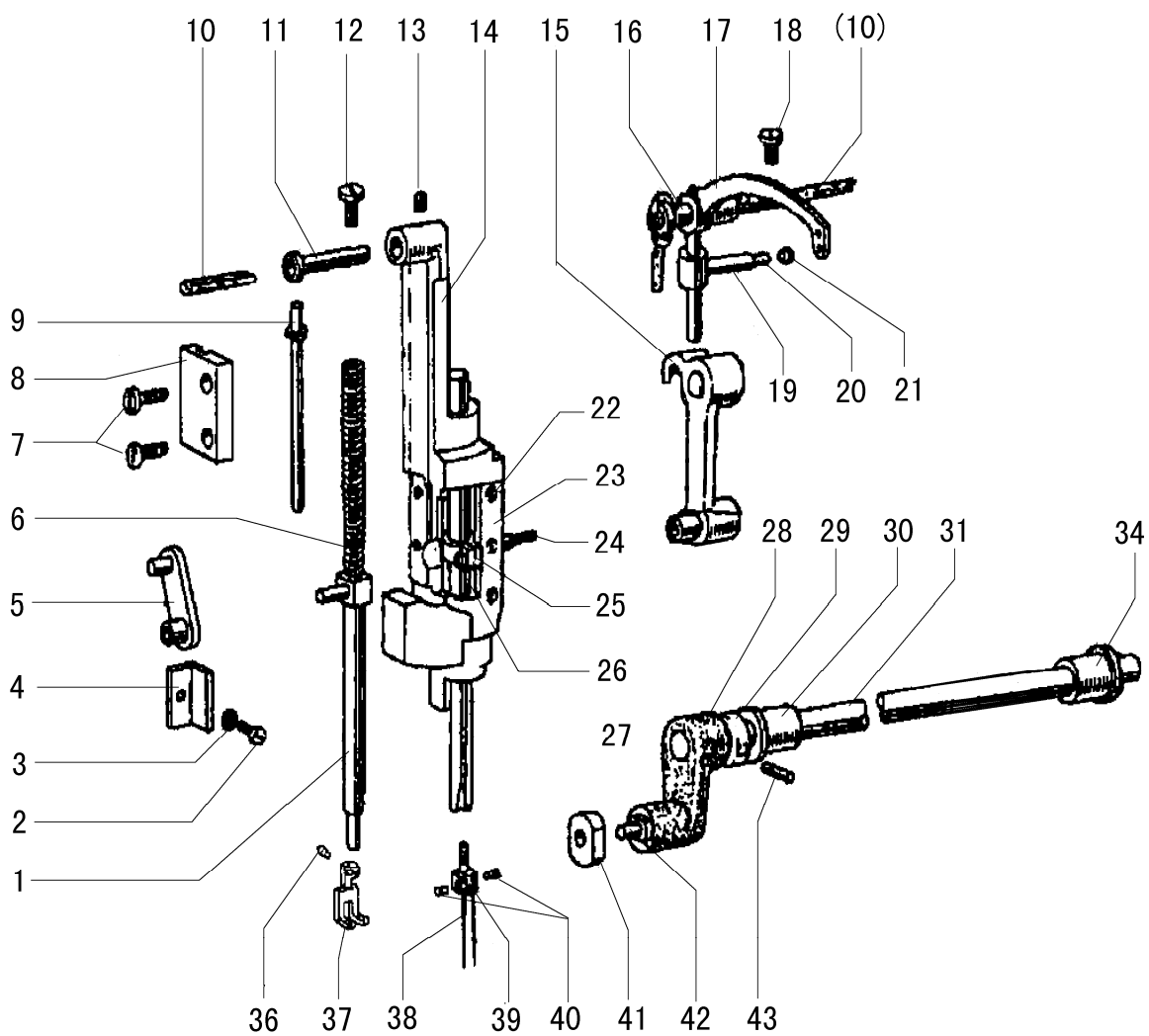

C. 针杆挑线、转筒送料部件

序号	样本编号	名称	件数	备注
C01	H4725F8001	内压紧杆	1	
C02	H3400C2020	六角带槽螺栓	1	
C03	H3200I2030	垫片	1	
C04	H3400C2010	针杆导向块	1	
C05	H4726F8001	杠杆连杆	1	
C06	H4729F8001	内压脚弹簧	1	
C07	H4753E8001	提升架紧定螺钉	2	SM11/64(40)×17.5
C08	H4728F8001	滑块导轨	1	
C09	H4730F8001	压簧顶杆	1	
C10	H2405D1122	油线	2	
C11	H4706F8001	针杆摆动架销	1	
C12	H4707F8001	压紧杆螺钉	1	
C13	HA3411D308	针杆摆动架紧定螺钉	1	SM15/64(28)×7
C14	H4719F8001	针杆摆动架	1	
C15	H4717F8001	针杆挑线连杆	1	
C16	H2405D1121	挑线杆铰链轴	1	
C17	H4712F8001	挑线杆	1	
C18	HA110D0672	主动轮螺钉	1	SM15/64(28)×12
C19	H2405D1112	滑杆	1	
C20	H24211D405	滑杆油线	1	
C21	H24211D305	滑杆塞子	1	
C22	H32111D304	沉头螺钉	6	SM3/32(56)×4
C23	H4721F8001	垫片	2	
C24	H3204D6513	羊毛毡	1	
C25	H4722F8001	针杆夹头	1	
C26	H32111D604	圆柱头螺钉	1	SM9/64(40)×8.5
C27	H4724F8001	针杆	1	
C28	H3406C0672	针杆架摆动曲柄(左)	1	
C29	H4734F8001	垫圈	1	
C30	H3204B0652	摆动轴轴套	1	
C31	HF104F8001	针杆架摆动曲柄轴	1	
C34	HF127B8001	摆动轴轴套	1	
C35	H2010J0066	螺母	2	
C36	HA700F2100	内压脚紧定螺钉	1	SM11/64(40)×7
C37	H4746F8001	内压脚(1/2")	1	
	H4744F8001	内压脚(5/16)	1	
C38	JZDP1700G2302	机针	2	DP×17 23#
C39	H4755F8001	机针夹头(1/2")	1	
	H4753F8001	机针夹头(5/16)	1	
C40	H32132D104	机针支紧螺钉	2	SM9/64(40)×3
C41	H4759F8001	滑块	1	

C. 针杆挑线、转筒送料部件

序号	样本编号	名 称	件数	备 注
C42	H3406C0671	支撑轴螺钉	1	SM15/64(28)×10
C43	H602040240	销	1	4×24

D. 压脚部件

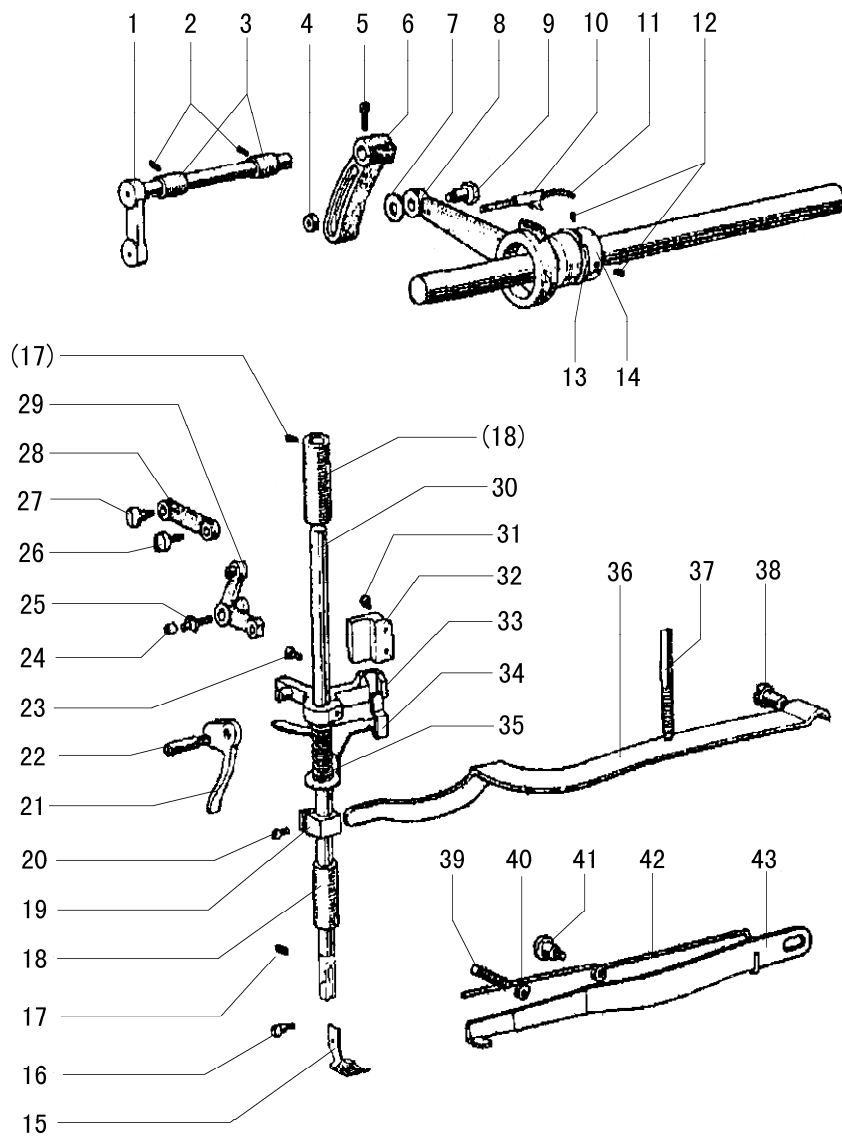

D. 压脚部件

序号	样本编号	名称	件数	备注
D01	H4705E8001	压脚提升曲柄轴	1	
D02	H4706E8001	压脚提升曲柄轴轴套螺钉	2	SM1/4(24)×7
D03	H4707E8001	压脚提升曲柄轴轴套	2	
D04	H0030550608	螺母	1	
D05	H3115F0671	调节曲柄螺钉	1	SM1/4(28)×16
D06	H4709E8001	调节曲柄	1	
D07	H2013J0065	垫圈	1	
D08	H2014J0066	偏心轮连杆	1	
D09	H2000J2100	调节螺钉	1	M6×0.75
D10	H20111C106	偏心连杆毛毡夹	1	
D11	H4713E8001	油绳	1	
D12	HA307C0662	压脚提升偏心轮螺钉	2	SM1/4(40)×6
D13	H007009250	挡圈	1	
D14	H4714E8001	压脚提升偏心轮	1	
D15	H4763E8001	外压脚(1/2")	1	
	H4761E8001	外压脚(5/16)	1	
D16	H3200E2020	外压脚紧定螺钉	1	SM1/8(44)×4
D17	H4708D8001	紧定螺钉	2	SM1/4(24)×13
D18	H4744E8001	外压紧杆下轴套	2	
D19	H4746E8001	压紧杆弹簧架	1	
D20	H2404I0034	旋梭定位勾定位螺钉	1	SM9/64(40)×8.5
D21	H4748E8001	压脚提升扳手	1	
D22	H4749E8001	压脚扳手螺钉	1	SM11/64(40)×8.5
D23	H4753E8001	提升架紧定螺钉	1	SM11/64(40)×17.5
D24	H4717E8001	滑柱	1	
D25	H2004J0655	送料曲柄导柱轴	1	
D26	H4718E8001	曲柄连杆螺钉	1	SM11/64(32)×6
D27	H2004J0662	压脚送料曲柄连杆螺钉	1	SM1/4(40)×5
D28	H4719E8001	曲柄连杆	1	
D29	H4715E8001	压脚提升杠杆	1	
D30	H4754E8001	压紧杆	1	
D31	HA111G0683	导轨螺钉	2	SM11/64(40)×12
D32	H4723E8001	压紧杆提升架导轨	1	
D33	H4752E8001	压紧杆提升架	1	
D34	H4768E8001	松线推板	1	
D35	H4767E8001	弹簧	1	
D36	H4730E8001	压紧杆簧	1	
D37	H4729E8001	调压螺钉	1	
D38	H3100G2170	压簧支撑螺钉	1	SM1/4(24)×11
D39	H4725E8001	复位弹簧螺钉	1	SM1/4(24)×19
D40	H4726E8001	复位弹簧螺帽	1	
D41	H3100G2130	膝控提升杠杆螺钉	1	SM1/4(24)×7
D42	H4727E8001	膝控提升杠杆复位弹簧	1	
D43	H4728E8001	膝控提升杠杆	1	

E. 倒缝、针距调节部件

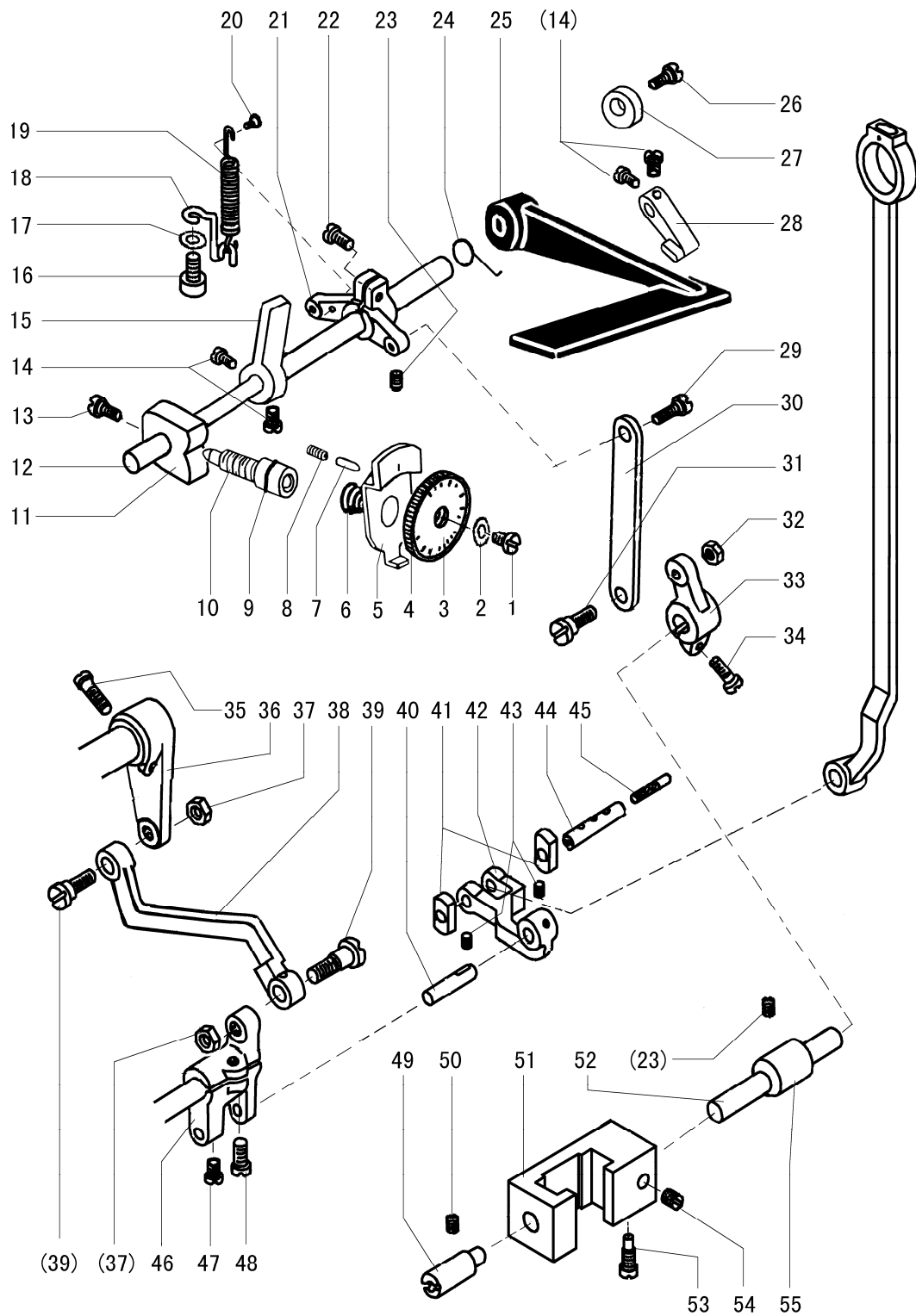

E. 倒缝、针距调节部件

序号	样本编号	名称	件数	备注
E01	HA720F0686	标盘螺钉	1	SM3/16(28)×12
E02	HA720F0685	标盘螺钉衬套	1	
E03	H5341H8001	标盘面板	1	
E04	HA7421F120	针距标盘	1	
E05	HA720F0683	针距标盘定位板	1	
E06	HA720F0687	针距按键簧	1	
E07	HA700F2030	止动销	1	
E08	HA100F2090	止动销弹簧	1	
E09	HA109F0674	针距调节螺杆密封圈	1	14×2.4
E10	HA720F0681	针距调节螺杆	1	
E11	HH61F18001	针距调节曲柄	1	
E12	HH70F88001	倒缝操纵杆轴	1	
E13	HA104F0654	牙叉铰链轴螺钉	1	SM15/64(28)×10
E14	HA113F0684	倒缝操纵杆螺钉	4	SM15/64(28)×8.5
E15	HH71F08001	倒缝推动曲柄	1	
E16	HA100H2150	拉簧架螺钉	1	SM9/64(40)×11
E17	H005004050	垫圈	1	
E18	H5330H8001	拉簧架	1	
E19	HG207G8001	倒缝操纵杆拉簧	1	
E20	H5329H8001	拉簧螺钉	1	SM9/64(40)×4
E21	H5327H8001	倒缝操纵杆短轴曲柄	1	
E22	H5343H8001	倒缝操纵杆短轴曲柄夹紧螺钉	1	SM3/16(32)×16
E23	HA3411D308	倒缝台长轴轴套螺钉	2	SM15/64(28)×7
E24	H4939L8001	倒缝扳手复位弹簧	1	
E25	HH70F98001	倒缝操纵杆	1	
E26	H4937L8001	倒缝扳手限位螺钉	1	SM15/64(28)×6
E27	H4938L8001	倒缝扳手限位橡皮圈	1	
E28	H4936L8001	倒缝扳手拉杆块	1	
E29	H5333H8001	倒缝操纵杆短轴连杆螺钉	1	SM3/16(32)×8.5
E30	HH60F98001	倒缝台长轴曲柄连杆	1	
E31	H5324H8001	倒缝台长轴曲柄连杆螺钉	1	SM3/16(32)×13.5
E32	H5325H8001	倒缝台长轴曲柄连杆螺母	1	SM3/16(32)×3.6
E33	HH70F68001	倒缝台长轴曲柄	1	
E34	HA111G0683	倒缝台长轴曲柄夹紧螺钉	1	SM11/64(40)×12
E35	H5320H8001	针杆摆动连杆夹紧螺钉	1	SM15/64(28)×23.5
E36	HBF6252081	针杆摆动连杆	1	
E37	H2010J0066	连杆螺母	2	SM9/32(28)×3.6
E38	HH60F68001	连杆	1	
E39	H5317H8001	连杆螺钉	2	SM9/32(28)×13.3
E40	H5315H8001	倒缝台滑块连杆曲柄轴	1	
E41	H5309H8001	倒缝台滑块	2	
E42	H5313H8001	倒缝台滑块连杆	1	
E43	HA711B0681	倒缝台滑块螺钉	2	SM9/64(40)×4.5
E44	H5311H8001	倒缝台滑块轴	1	

E. 倒缝、针距调节部件

序号	样本编号	名 称	件数	备 注
E45	H5312H8001	倒缝台滑块轴油线	1	
E46	HBFG251081	倒缝台滑块连杆曲柄	1	
E47	HA700F2100	倒缝台滑块连杆曲柄轴螺钉	1	SM11/64(40)×7
E48	HA800F2020	倒缝台滑块连杆曲柄夹紧螺钉	1	SM15/64(28)×13.5
E49	HH70F48001	倒缝台短轴	1	
E50	HA100C2020	倒缝台短轴定位螺钉	1	SM15/64(28)×10
E51	H5305H8001	倒缝台	1	
E52	H5306H8001	倒缝台长轴	1	
E53	HA100F2130	倒缝台长轴紧定螺钉	1	SM15/64(28)×5
E54	HA300B2080	倒缝台长轴螺钉	1	SM15/64(28)×6.8
E55	H5307H8001	倒缝台长轴轴套	1	

F. 下轴、抬牙送布部件

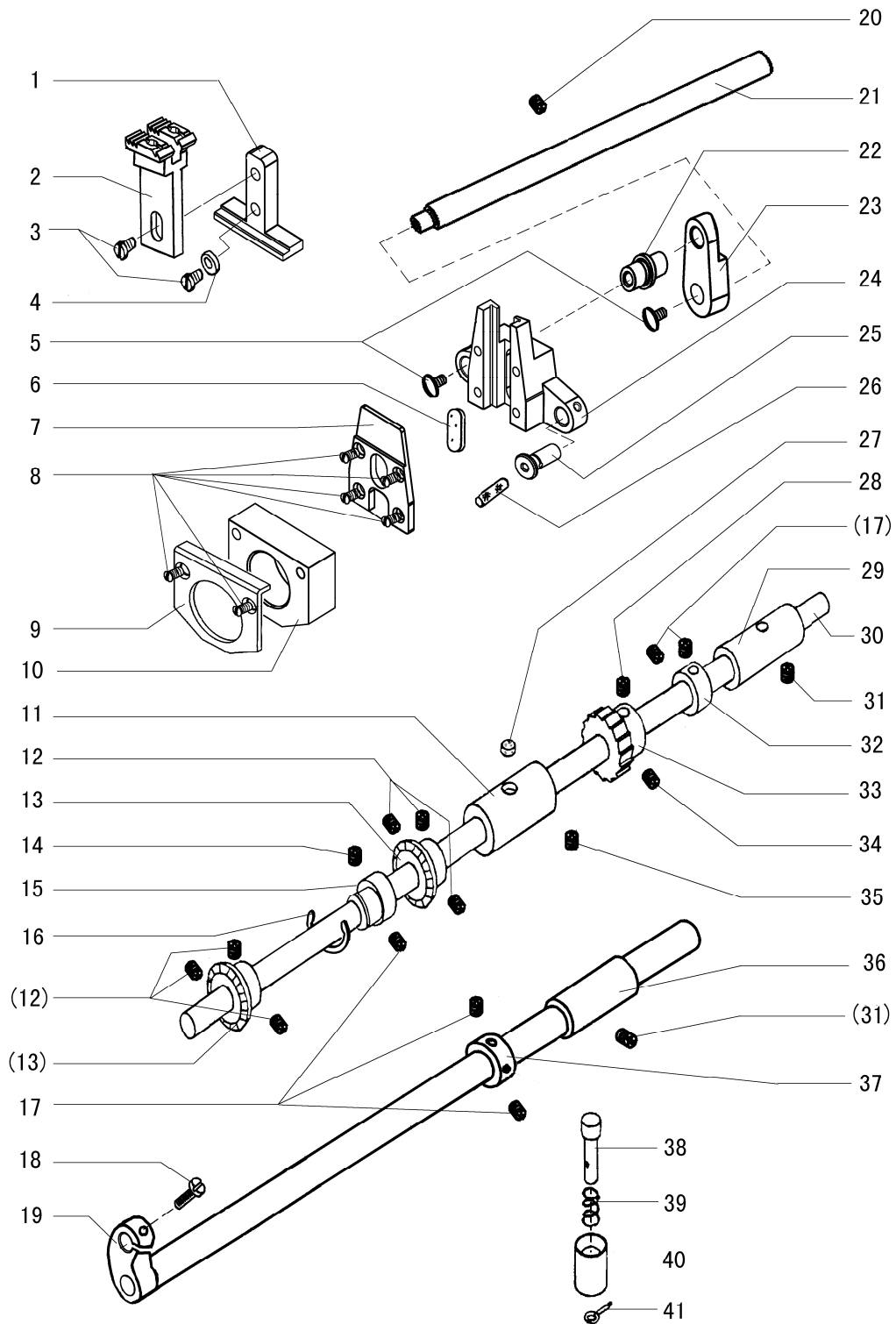

F. 下轴、拾牙送布部件

序号	样本编号	名称	件数	备注
F01	HBG6255081	送布曲柄滑块	1	
F02	HN20G88001	送布牙(1/2")	1	
		送布牙(5/16)	1	
F03	H4967K8001	限位板螺钉	2	SM11/64(40)×7.2
F04	HBG6260081	垫圈	1	
F05	HA100G2100	牙架连杆螺钉	2	
F06	HBG6254081	送布曲柄羊毛毡	1	
F07	HN21G18001	送布曲柄压片	1	
F08	HA7311C306	送布凸轮垫圈螺钉	6	
F09	HBG6258081	拾牙偏心凸轮座压片	1	
F10	HBG6257081	拾牙偏心凸轮座	1	
F11	HE111D8001	下轴轴套(左)	1	
F12	HG214G8001	内六角紧定螺钉	6	东洁 SM1/4(40)
F13	HE110D8001	下轴锥齿轮	2	
F14	HE105C8001	拾牙偏心定位螺钉	1	SM13/64(32)×4.7
F15	HBG6251081	拾牙偏心凸轮	1	
F16	HF909H8001	C型挡圈	1	
F17	HE013H8001	下轴紧圈螺钉	5	SM13/64(32)×4.3
F18	HE119E8001	送布轴连接短销紧定螺钉	1	SM5/32(40)×9
F19	HN20G57101	送布轴组件	1	
F20	HA100C2130	针杆轴套(下)螺钉	1	SM11/64(40)×2.7
F21	HN20G98001	传动轴	1	
F22	HA111G0682	拾牙轴曲柄铰链轴	1	
F23	HBG6263081	传动轴连接曲柄	1	
F24	HN21G08001	送布曲柄	1	
F25	HE116E8001	送布轴连接短销	1	
F26	HE117E8001	送布轴连接短销油线	1	
F27	HE112D8001	下轴轴套(左)羊毛毡	1	
F28	HE043C8001	下轴棘轮紧定螺钉	1	
F29	HH70G58001	下轴轴套(右)	1	
F30	HN20G48001	下轴	1	
F31	HE034G8001	下轴轴套定位螺钉	2	SM1/4(32)×7
F32	HE105D8001	下轴紧圈	1	
F33	HE106D8001	下轴棘轮	1	
F34	HE107D8001	下轴棘轮定位螺钉	1	
F35	HE013C8001	下轴轴套(左)定位螺钉	1	SM17/64(24)×6.5
F36	H5321E8001	送布轴轴套(右)	1	
F37	H4105D0651	送布轴紧圈	1	
F38	HN21D28001	安全离合器轴	1	
F39	H4107D0672	安全离合器弹簧	1	
F40	HN21D18001	安全离合器轴套	1	
F41	H601016100	安全离合器轴销	1	

G. 旋梭架部件

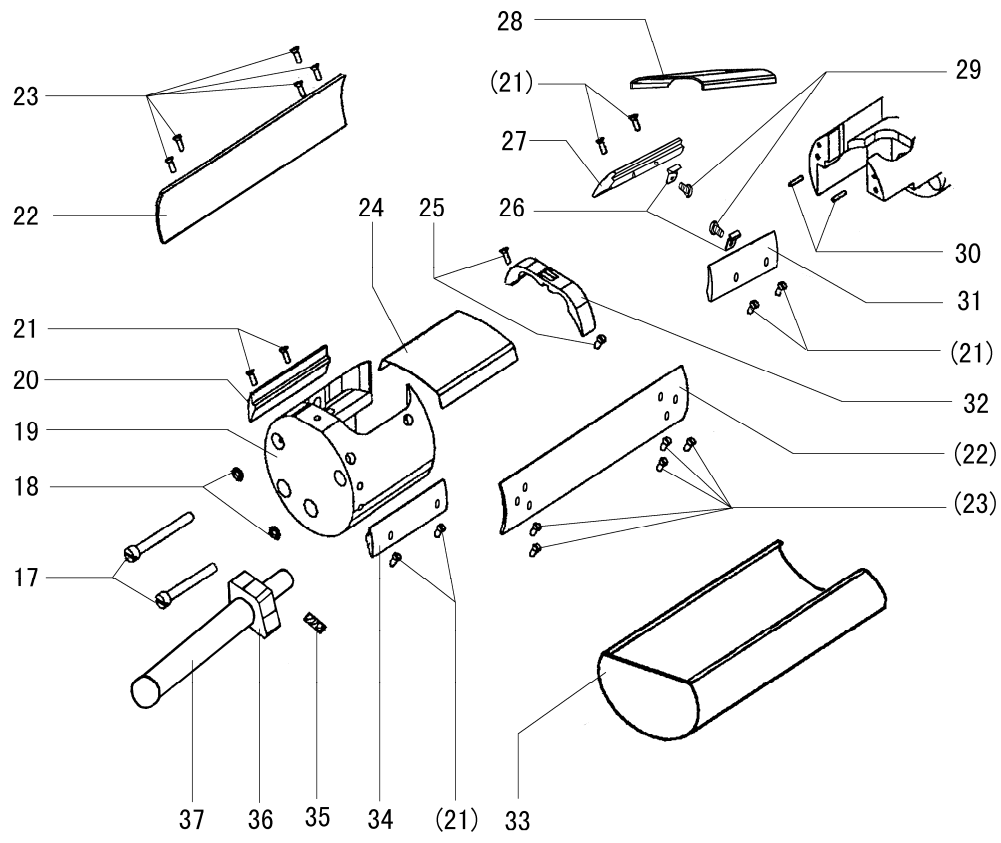
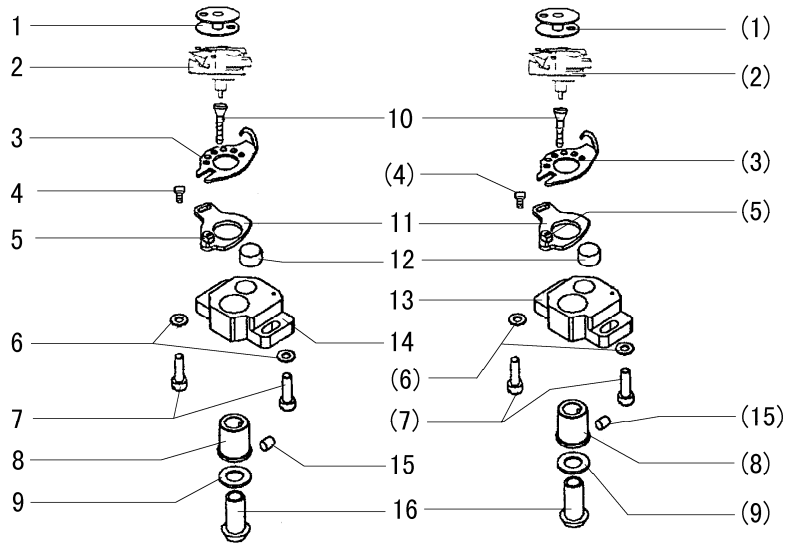

G. 旋梭架部件

序号	样本编号	名称	件数	备注
G01	HD806I8001	梭芯	2	
G02	HH60H67101	旋梭组件	2	KRT8-BL (佐文)
G03	HE117B8001	旋梭定位勾	2	
G04	HE046C8001	旋梭安装架挡板螺钉	2	SM0.1339(36)×6
G05	HE116B8001	旋梭安装架挡板滑块	2	
G06	HE121B8001	旋梭安装架螺钉垫圈	4	
G07	HE120B8001	旋梭安装架螺钉	4	SM13/64(32)×16.5
G08	HE125B8001	旋梭架锥齿轮轴套	2	
G09	HE124B8001	旋梭架锥齿轮垫片	2	
G10	H2404I0652	旋梭安装螺钉	2	SM9/64(40)
G11	HE127B7101	旋梭安装架挡板组件	2	
G12	HE126B8001	旋梭安装架羊毛毡	2	
G13	HE147B8001	旋梭安装架(右)	1	
G14	HE119B8001	旋梭安装架(左)	1	
G15	HE028E8001	旋梭架锥齿轮轴套紧定螺钉	2	SM7/32(32)×7
G16	HE123B8001	旋梭架锥齿轮	2	
G17	HE143B8001	旋梭安装架支架连接螺钉	2	SM13/64(32)
G18	H005009050	旋梭安装架支架连接垫圈	2	
G19	HE113B8001	旋梭安装架支架	1	
G20	HH61H28001	前推板导轨(左)(1/2")	1	
	HN22H78001	前推板导轨(左)(5/16)	1	
G21	HE130B8001	推板导轨螺钉	8	SM0.1339(36)×8.2
G22	HE144B8001	旋梭安装架支架连接板	2	
G23	HE145B8001	旋梭安装架支架连接板螺钉	10	SM11/64(40)×9
G24	HH60H97101	前推板组件(1/2")	1	
	HN22H97101	前推板组件(5/16)	1	
G25	HE137B8001	针板螺钉	2	SM11/64(32)×10
G26	HN20H98001	盖板板簧	2	
G27	HN22H08001	盖板导轨(后)(1/2")	1	
	HN22H58001	盖板导轨(后)(5/16)	1	
G28	HN22H28001	盖板(1/2")	1	
	HN22H48001	盖板(5/16)	1	
G29	H5727B8001	盖板板簧螺钉	2	SM1/8(44)×3.4
G30	HE142B8001	旋梭安装架支架定位销	2	
G31	HN21H98001	盖板导轨(前)(1/2")	1	
	HN22H68001	盖板导轨(前)(5/16)	1	
G32	HN22H38001	针板(1/2")	1	
	HN21H58001	针板(5/16)		
G33	HN21H08001	端盖	1	
G34	HH61H38001	前推板导轨(右)(1/2")	1	
	HN22H88001	前推板导轨(右)(5/16)		
G35	HE114B8001	送布轴连接销紧定螺钉	1	M4×4
G36	H4111E0682	送布轴连接销羊毛毡	1	
G37	HE115B8001	送布轴连接销	1	

H. 夹线、过线部件

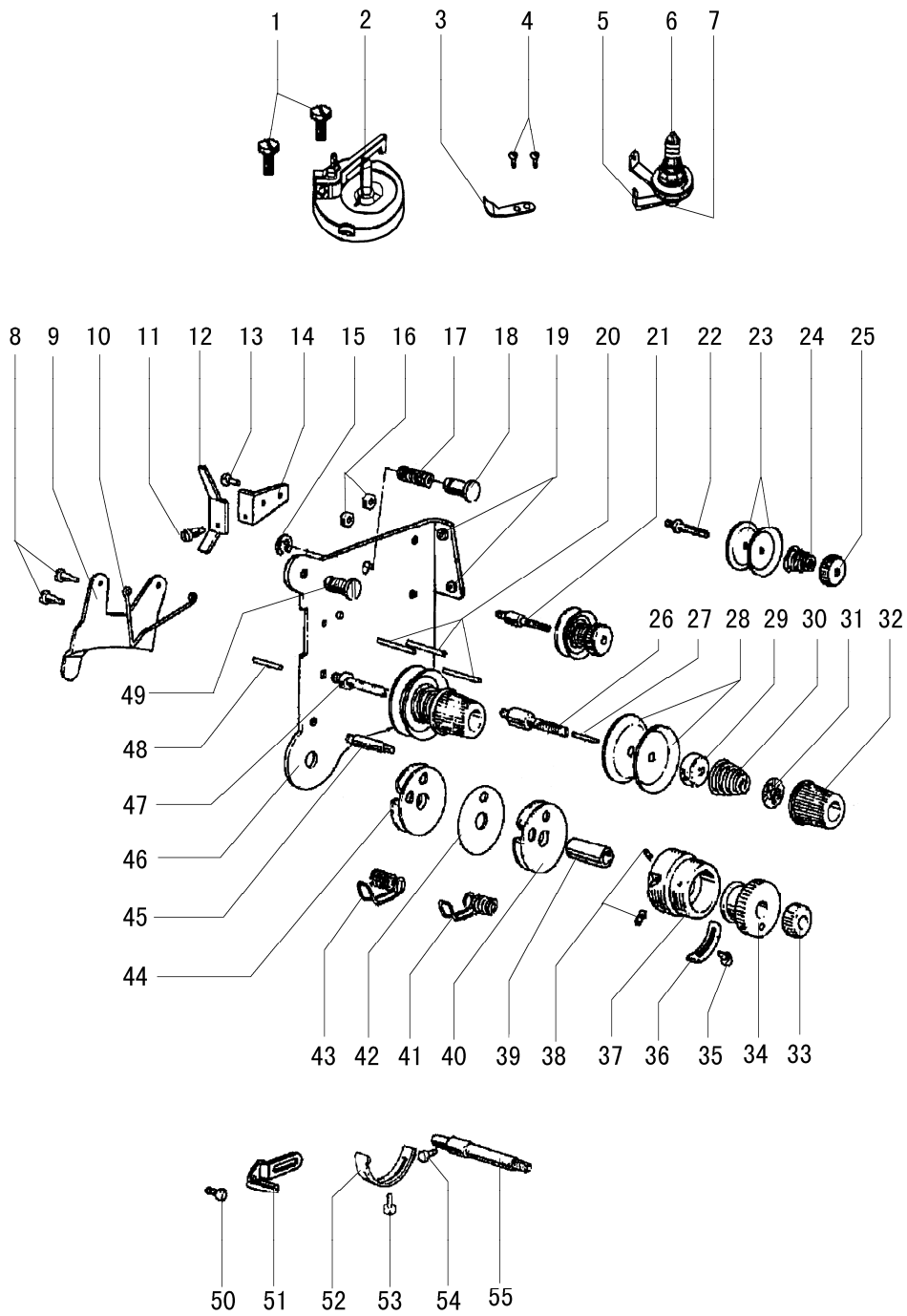

H. 夹线、过线部件

序号	样本编号	名称	件数	备注
H01	H3107G0662	绕线器定位螺钉	2	
H02	H7007D7101	绕线器组件	1	
H03	H6756B8001	剪切板	1	
H04	HA500C2070	剪切板螺钉	2	SM9/64(28)×5
H05	H6662B8001	过线勾	1	
H06	H7014D7101	夹线器组件	1	
H07	H7016D8001	垫块	1	
H08	H3221B6811	松线压板螺钉	2	SM9/64(40)×3
H09	H3221B3142	松线板	1	
H10	H3221B6812	松线板压弹簧	1	
H11	H4705C8001	阶梯螺钉	1	
H12	H4706C8001	摆杆	1	
H13	HA7311C306	送布凸轮垫圈螺钉	1	SM9/64(40)×7
H14	H4707C8001	安装板	1	
H15	H007013050	挡圈	1	
H16	H3221B6810	六角螺母	2	
H17	H4708C8001	按钮复位弹簧	1	
H18	H4709C8001	按钮	1	
H19	H3221B0681	瓷管	2	
H20	H3221B0682	过线销	3	
H21	H3221B0685	夹线调节螺钉	1	
H22	H3221B0683	夹线调节螺钉	1	
H23	HA112B0693	夹线板	4	
H24	H3221B0684	夹线弹簧	2	
H25	HA710B0671	夹线螺母	2	SM11/64(40)×6
H26	H3221B0689	夹线调节螺钉	1	
H27	H3221B6816	过线钉	1	
H28	HA310B0705	夹线板	4	
H29	HA310B0702	松线板	2	
H30	H4710C8001	夹线簧	2	
H31	HA115B7010	夹线螺母止动板	2	
H32	HA310B0701	夹线螺母小组件	2	
H33	H32481B721	螺母	1	SM1/4(40)×4.5
H34	H32481B621	套筒	1	
H35	H32481BC21	圆柱头螺钉	1	SM9/64(40)×6
H36	H32481BB21	止动块	1	
H37	H32481B921	导向套	1	
H38	H32481B521	紧定螺钉	2	SM11/64(40)×10
H39	H32481B821	轴套	1	
H40	H32481BF21	过线板组件	1	
H41	H4712C8001	挑线簧	1	
H42	H32481BE21	过线板	1	
H43	H4713C8001	挑线簧	1	
H44	H32481BD21	过线板组件	1	

H. 夹线、过线部件

序号	样本编号	名 称	件数	备 注
H45	H32481B421	阶梯螺钉	1	
H46	H3221B6820	夹线调节器安装板	1	
H47	H3221B0686	夹线调节螺钉	1	
H48	H3221B6817	过线钉	1	
H49	HA300C2030	挑线杆防护罩螺钉	1	SM11/64(40)×8
H50	HA106B0676	面板线勾螺钉	1	SM9/64(40)×6
H51	H3306B0661	线勾	1	
H52	H3221B6819	止动块	1	
H53	H3200B2100	圆柱头螺钉	1	SM9/64(40)×6.5
H54	H3230K0751	紧定螺钉	1	SM11/64(40)×10
H55	H32481B121	阶梯轴螺钉	1	

I. 气动控制部件

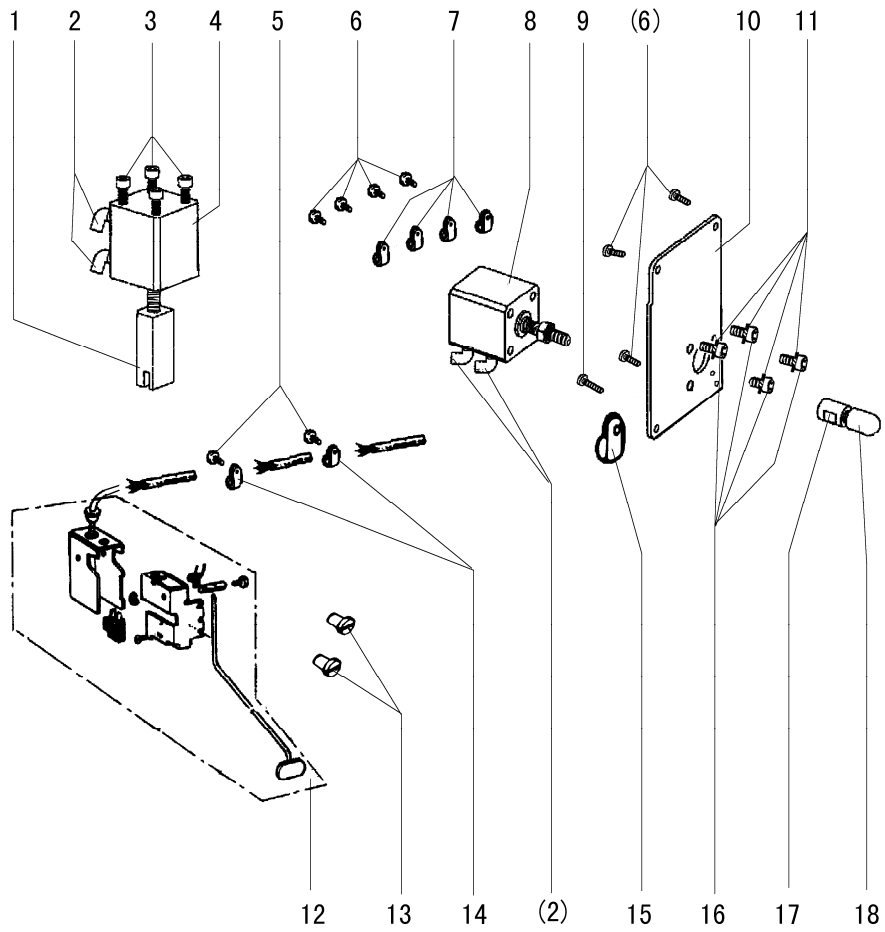

I. 气动控制部件

序号	样本编号	名 称	件数	备 注
I01	H0606N8001	压块	1	
I02	H4916G8001	快插接头（弯头）	4	Φ6-M5
I03	H415050450	内六角圆柱头螺钉	4	
I04	H0607N8001	气缸	1	SDA25×25-B
I05	HA300B2130	夹边座螺钉	2	SM11/64(40)×5.5
I06	HA300B2170	盖板螺钉	7	SM11/64(40)×9
I07	HA700Q0050	尼龙夹（HP-8N）	4	
I08	H4915G8001	气缸	1	SDA25×25-B
I09	HA100I2090	油泵体螺钉	1	SM11/64(40)×13
I10	HN20J78001	后盖板（右）	1	
I11	H005008060	弹簧垫圈	4	发黑
I12	HN20J57101	倒缝开关组件	1	
I13	H4918L8001	开关盒安装螺钉	2	
I14	H4980K8001	电线夹头	1	
I15	HD44JM8001	尼龙夹头	1	
I16	H415060200	内六角圆柱头螺钉	4	发黑
I17	H4914G8001	倒缝气缸接杆	1	
I18	H4913G8001	倒缝推动触头	1	

J. 附件

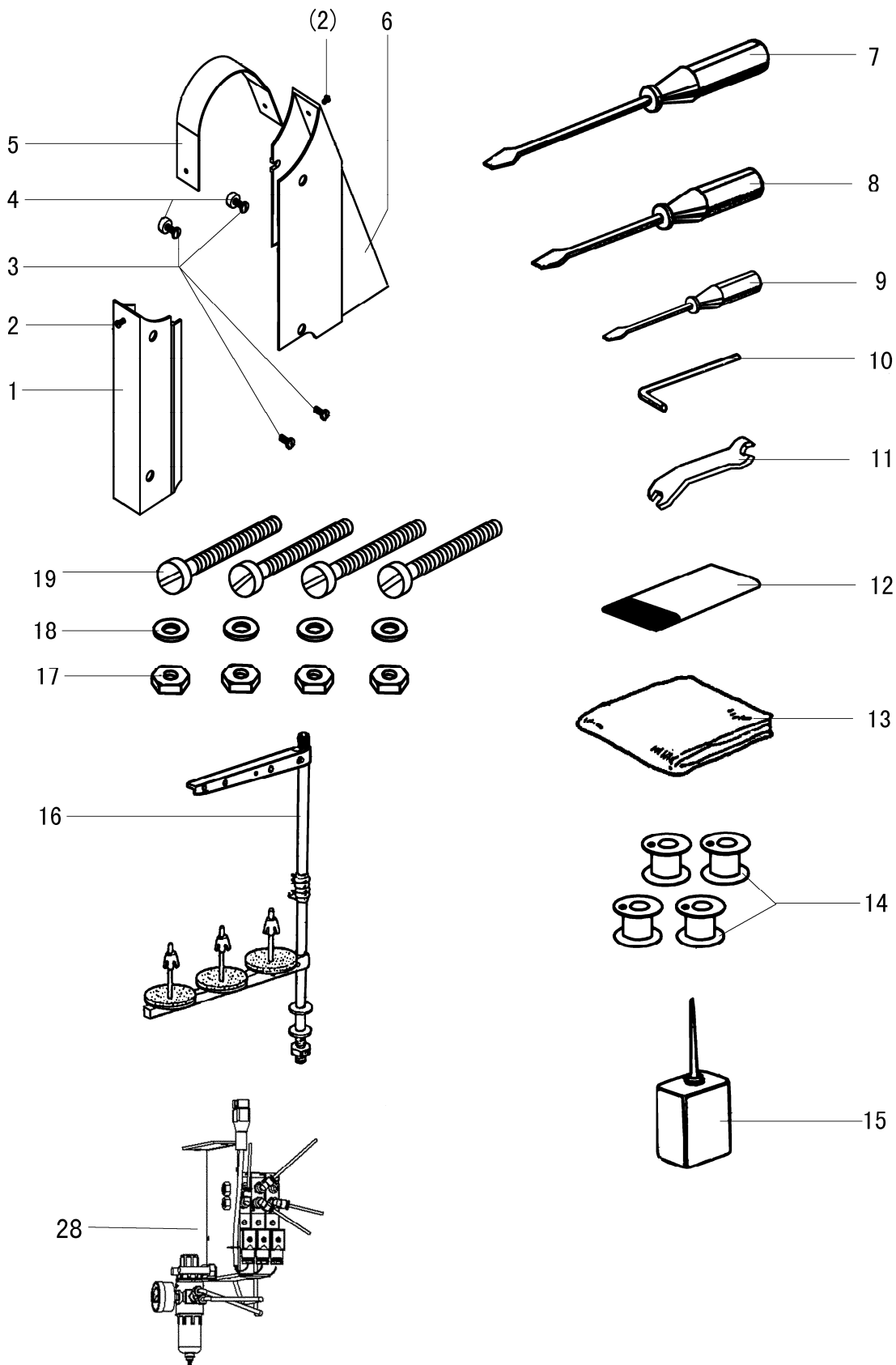

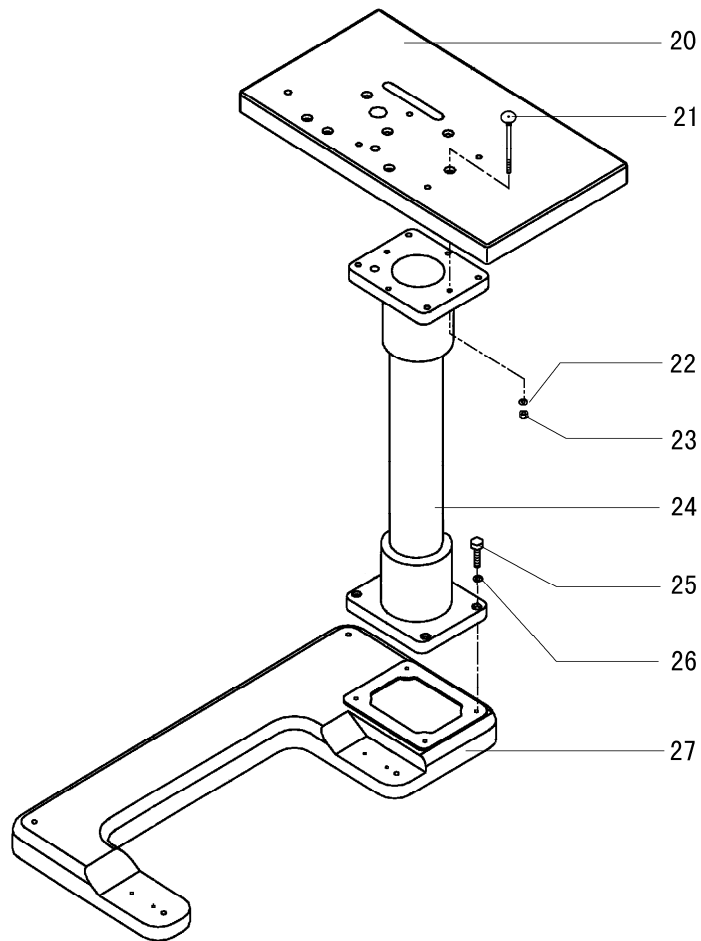

J. 附件

序号	样本编号	名 称	件数	备 注
J01	HH70I68001	皮带罩（左）	1	
J02	H200000360	皮带罩上螺钉	2	SM11/64(40)×6
J03	H0207L8001	皮带罩安装螺钉	4	SM15/64(28)×18
J04	H6760B8001	垫块	2	
J05	H6307L8001	皮带罩（上）	1	
J06	HN22K08001	皮带罩（右）	1	
J07	HA300J2070	螺丝刀（大）	1	
J08	HA300J2200	螺丝刀（中）	1	
J09	HA300J2210	螺丝刀（小）	1	
J10	HB00001060	内六角扳手	1	
J11	HE105I8001	双头扳手	1	
J12	JZDP1700G2302	机针	6	DP×17 23#
J13	HF104K8001	机罩	1	
J14	HD806I8001	梭芯	4	
J15	H200400069	油壶	1	
J16	H3200L0120	线架组件	1	
J17	H003002120	1型六角螺母	4	
J18	H005001120	平垫圈	4	
J19	H103120120	六角头螺栓	4	M12×120
J20	HH70J98001	台板	1	
J21	H125100900	大半圆头方劲螺栓	4	M10×90
J22	H005001100	平垫圈	4	
J23	H003002100	1型六角螺母	4	
J24	H8915K8001	机架立座	1	
J25	H103120500	六角头螺栓	4	M12×50
J26	H005008120	弹簧垫圈	4	
J27	H8911K8001	机架底座	1	
J28	GJD-2	过滤减压阀及电磁阀组件	1	

上海标准海菱缝制机械有限公司
SHANGHAI BIAOZHUN HAILING SEWING MACHINERY CO., LTD.

地址: 上海市松江区850号

ADD: No.850, ShuLin Road, SongJiang District, Shanghai, P.R. China

邮编: 201612

Zip Code: 201612

内销业务: 电话: 86-21-64061284 传真: 86-21-64462799

零件服务: 电话: 86-21-64851424 传真: 86-21-64069792

Overseas Business: TEL: 86-21-64853303 FAX: 86-21-64854304

E-mail: sales@highlead.com.cn <http://www.highlead.com.cn>

制造商保留因技术改进而更改内容的权利, 恕不另行通知

2018年3月印制